

**RESERVD ELSLISTA
SPARE PART CATALOGUE
ERSATZTEILLISTE**



Banddiskmaskin

WTF2

WTF3

WTF4

• Inmatning	- L=700	4-5
• Grind		6-7
• Disktankar	- tank + plåtar - avlopp och disksystem, Fördisk L=600 - avlopp och disksystem, Fördisk, kemdisk L=900 - avlopp och disksystem, disktank L=1400 - uppvärmning tank	8-11 12-15 16-19 20-23 24-25
• Slutspolning	- spolsystem	26-29
• Vattenanslutningar		30-31
• Kopplingsskåp	- plåtar + eldetaljer - Eluppvärmd maskin - Ånguppvärmd maskin	32-35 36-39 40-41
• Torktunnel L=1100	- stativ + plåtar, - fläkt + avlopp - genomströmmare - eluppvärmd maskin - genomströmmare - ånguppvärmd maskin	42-45 46-47 48-51
• Energipaket ESD		52-55
• Kondensanläggning CU		56-59
• Utan ESD/CU		60-61
• Drivning - Transportband		62-63
• Utmatning	- L=700,1100 - L=1500	64-65 66-67
• Fästelement		68-70



PLATON SERVICE
8 (800) 500-34-41
www.platonservice.com

• Load section	- L=700	4-5
• Gate		6-7
• Washtanks	- tank + plates - drain and wash system, Prewash L=600 - drain and wash system, Prewash. wash tank L=900 - drain and wash system, wash tank L=1400 - heating tank	8-11 12-15 16-19 20-23 24-25
• Final rinse	- wash system	26-29
• Water connections		30-31
• Switch cabinet	- plates + electrical parts - electr. heated machine - steamheated machine	32-35 36-39 40-41

• Drying tunnel L=1100	- stand + plates, - fan + drain - booster - electr. heated machine - booster - steam heated machine	42-45 46-47 48-51
• Energy saving device, ESD		52-55
• Condensing unit CU		56-59
• Without ESD/CU		60-61
• Feeding and conveyor		62-63
• Unload section	- L=700, 1100 - L=1500	64-65 66-67
• Attachment element		68-70

DE	INHALTSVERZEICHNIS	Seite
----	---------------------------	--------------

• Zulaufstrecke	- L=700	4-5
• Gittertür		6-7
• Waschzone	- Tank und Bleche - Ablauf und Spülsystem vorwasch L=600 - Ablauf und Spülsystem vorwasch L=900 - Ablauf und Spülsystem wasch L=1400 - Erwärmung tank	8-11 12-15 16-19 20-23 24-25
• Nachspültank	- Spülsystem	26-29
• Wasseranschluß		30-31
• Schaltschrank	- Bleche + Elektr. Teile, - El. beheizt Maschine - Dampfbeheizt Maschine	32-35 36-39 40-41
• Trockenzone L=1100	- Gestell + Bleche, - Gebläse + Ablauf - Durclauferhitzer, El. beheizt Maschine - Durclauferhitzer, Dampfbeheizt Maschine	42-45 46-47 48-51
• Wärmerückgewinnung ESD		52-55
• Kondensationanlage CU		56-59
• Ohne ESD/CU		60-61
• Zuführung		62-63
• Auslaufstrecke	- L=700, 1100 - L=1500	64-65 66-67
• Befestigungsteile		68-70

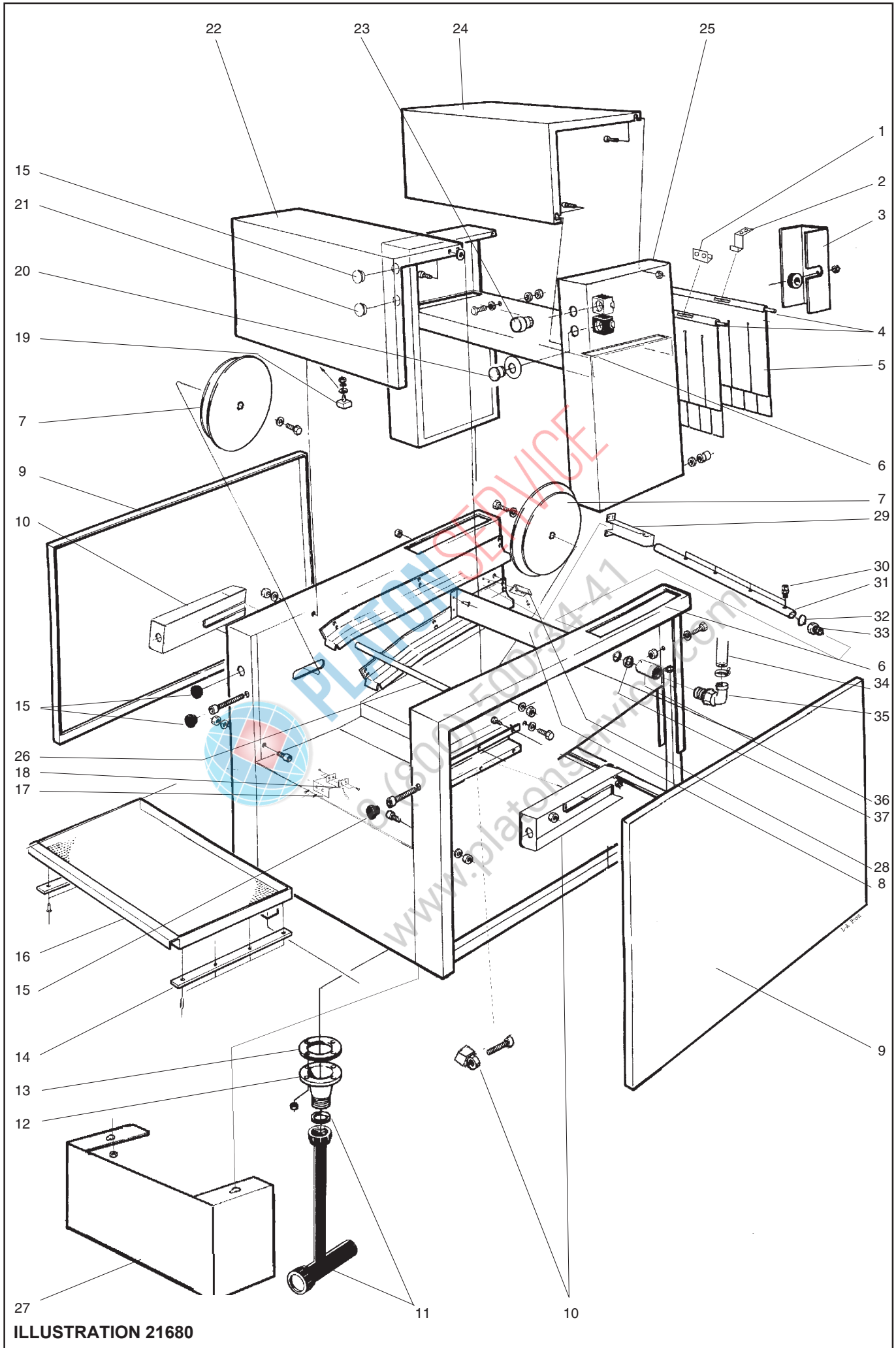

ILLUSTRATION 21680

Inmatning L=700 Load section L=700 Zulaufstrecke L=700			Illustration 21680			Utgåva Edition Ausgabe 6	Månad Month Monat 10	År Year Jahr 2010
Pos.	Antal Quantity Anzahl	Art.nr Art. no Art. Nr	Benämning	Description	Bezeichnung	Anm. Notes Anm.		
1	2	482 76 93-00	Gardinfäste	Curtain attachment	Vorhangbefestigung			
2	2	490 15 16-00	Gardinfäste	Curtain attachment	Vorhangbefestigung			
3	1	482 44 99-00	Skydd	Guard	Schutz	1).		
4	2	482 76 03-01	Gardinaxel	Curtain shaft	Vorhangachse			
5	2	490 15 10-00	Gardin	Curtain	Vorhang			
6	x	552 21 60-00	Plastlist	Plastic strip	Kunststoffleiste			
7	2	ST0 25 70-00	Bandvändare hjul	Conveyor wheel	Band Rad			
8	1	482 36 78-00	Skärmlåt	Baffle plate	Abschirmplatte			
9	2	ST0 25 73-00	Sida	Side detail	Seites hinten			
10	2	ST0 34 53-00	Bandspännaren kpl.	Conveyor tension adjuster	Bans spänner	2). 6).		
	2	ST0 67 01-00	Bandspännaren kpl.	Conveyor tension adjuster	Bans spänner	7).		
11	1	ST0 28 71-00	Avlopp inmatning	Drain loading section	Ablauf Zulaufstrecke	3).		
	1	ST0 28 71-01	Avlopp inmatning	Drain loading section	Ablauf Zulaufstrecke	4).		
12	1	475 77 84-00	Avloppsstos	Drain pipe connec	Ablaufstutzen			
13	1	477 73 94-00	Packning	Gasket	Dichtung			
14	2	ST0 25 86-00	Glidlist	Slide strip	Gleitprofil			
15	2	467 88 71-06	Ändavslutning	End plug	Endpfropfen	22 mm		
16	1	ST0 25 74-00	Silplåt kpl.	Streiner plate	Siebkasten platte			
17	1	491 38 74-00	Fäste	Attachement	Befestigung			
18	1	476 06 64-01	Magnetbrytare	Magn.Cont.Switch	Magnetausschate			
19	1	461 13 78-02	Magnet	Magnet	Magnet	1).		
20	1	428 07 60-00	Nödstoppsbrytare	Emergency switch	Notschalter			
22	1	ST0 27 87-00	Gavellucka kpl.	Side cover plate	Seite Deckplatte			
23	1	767 11 01-00	Tryckknapp	Push Button	Drücktaste	1).		
24	1	ST0 25 88-00	Slusstak	Top	Dach			
25	1	428 17 04-00	Sluss kpl	Steam hood cpl.	Dunsthaube kpl.	3).		
	1	428 17 04-01	Sluss kpl	Steam hood cpl.	Dunsthaube kpl.	4).		
26	1	482 01 42-00	Distansstång	Bar	Stange			
27	1	ST0 27 88-00	Täckplåt	Cover plate	Deckplatte			
28	2	499 67 94-00	Vinkelstöd	Angular profile	Stützwinkel			
29	1	ST0 34 17-00	Fäste förspolningsrör	Holder Pre-scrap pipe	Befestigung, Spülrohr	5).		
30	4	482 78 46-00	Dys	Nuzzle	Düse	5). 8010		
31	1	ST0 34 16-00	Spolrör	Rinsepipe	Spülrohr	5).		
32	1	740 43 15-14	O-ring	O-ring	O-ring	5). 17,3x2,4		
33	1	428 02 07-00	Spolrörsmuff	Rinse pipe sleeve	Spülrohrmuffe	5).		
34	x	552 00 11-00	Slang	Hose	Schlauch	5). 1/2"		
35	1	552 21 71-00	Slangnippel vinkel	Hose nipple angular	Schlauchnippel	5). 1/2"-15		
36	1	741 21 13-20	Muff	Sleeve	Muffe	5). 1/2"		
37	1	552 21 10-01	Packning	Gasket	Dichtung	5). 20/14 T=1,5		

1).WFT3, WFT4
2).Fr.o.m 2004 vecka 17
3)Vänstermatad
4).Högermatad
5).Top(A)
6).T.o.m 2007 vecka 37
7).Fr.o.m 2007 vecka 38

From 2004 week 17
Left feeded
Right feeded
To 2007 week 37
From 2007 week 38

Ab. 2004 wochen 17
Links Richtung
Rechts Richtung
Zu 2007 wochen 37
Ab. 2007 wochen 38

Fet stil = Ändring
Bold print = Change
Fettdruck = Änderung

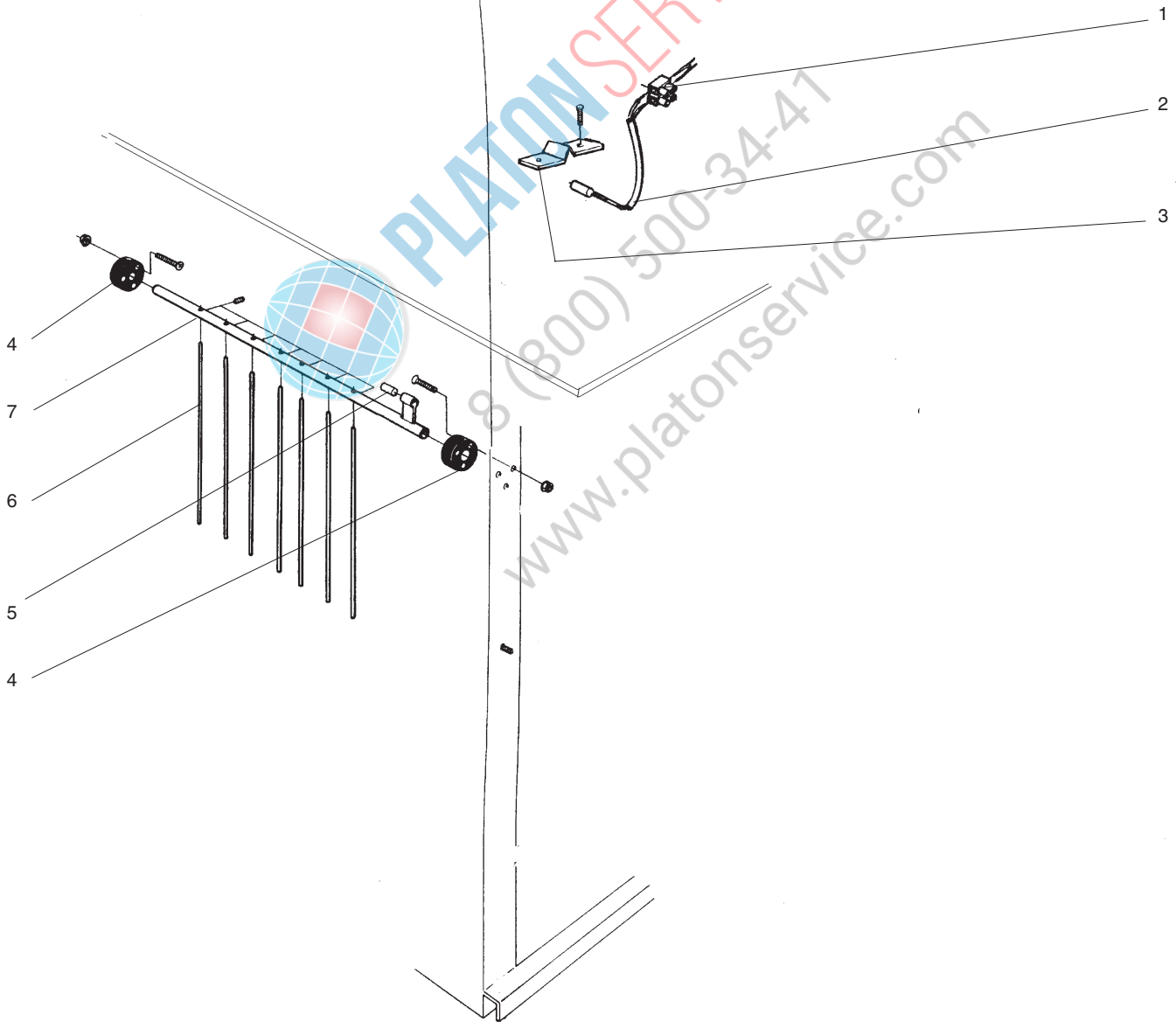
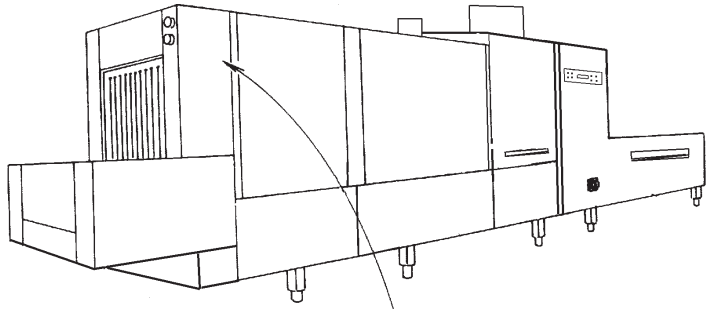

ILLUSTRATION 21681

Grind Gate Gittertür		Illustration 21681				Utgåva Edition Ausgabe 2	Månad Month Monat 10	År Year Jahr 2010
Pos.	Antal Quantity Anzahl	Art.nr Art. no Art. Nr	Benämning	Description	Bezeichnung	Anm. Notes Anm.		
1	2	762 72 12-55	Koppl. plint	Terminal block	Klemmeleiste			
2	2	476 01 36-02	Magnetbrytare	Magn.Cont.Switch	Magnetausschate			
3	1	482 61 51-00	Klamma	Clamp	Klemme			
4	4	481 72 89-00	Lager	Bearing	Lager			
5	2	477 74 93-00	Magnet	Magnet	Magnet			
6	7	462 16 19-07	Pinne	Dowel	Splint			
7	1	ST0 27 76-00	Grind	Gate	Gittertür			



PLATON SERVICE
8 (800) 500-34-41
www.platonservice.com

Fet stil = Ändring
Bold print = Change
Fettdruck = Änderung

1). Axelvstånd C-C=120mm Distance between shafts C-C=120mm Achsabstand C-C=120mm
2). Axelvstånd C-C=100mm Distance between shafts C-C=100mm Achsabstand C-C=100mm

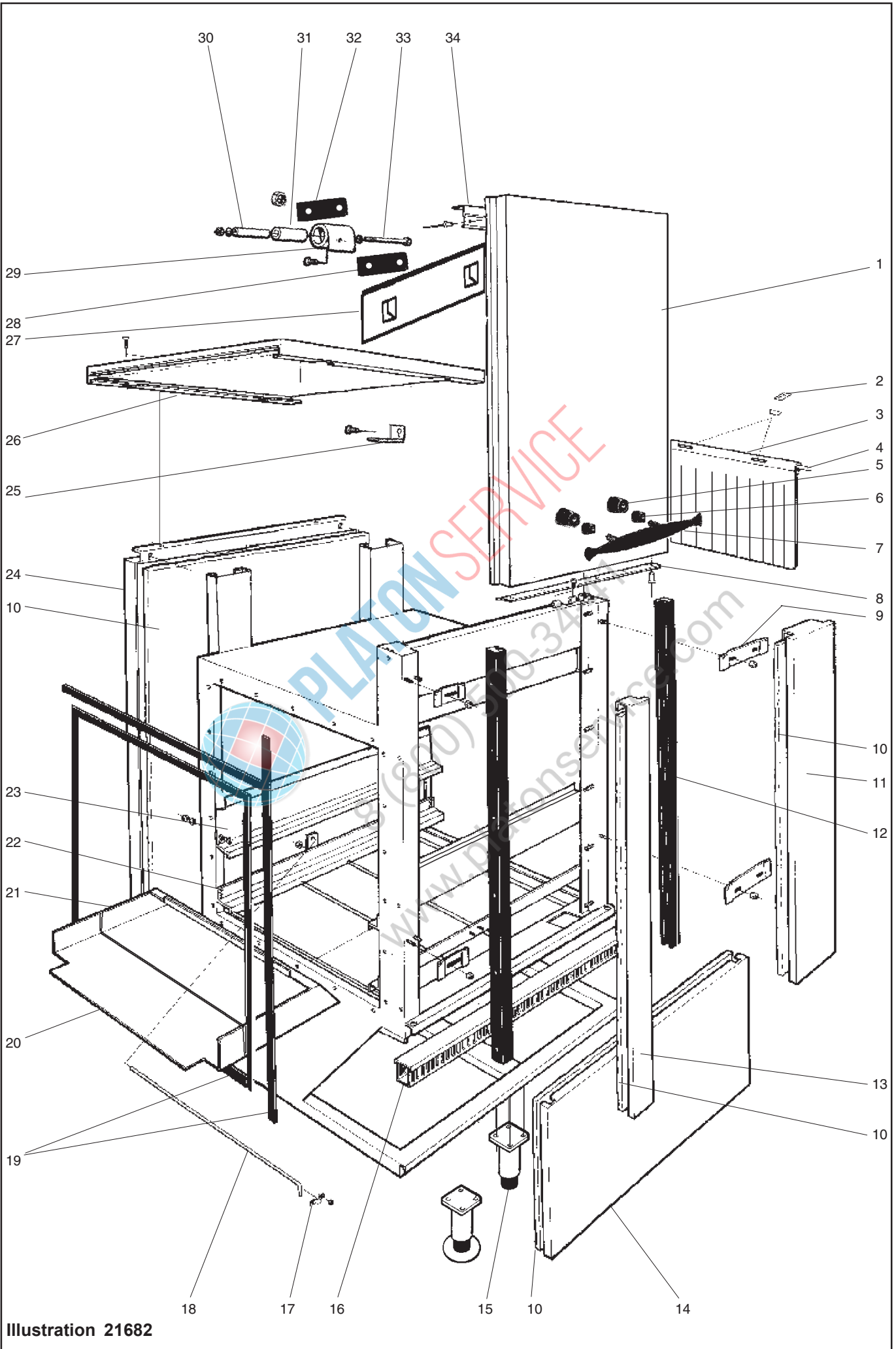

Illustration 21682

Fördisktank + disktank, plåtar
Prewash tank + wash tank, plates
Vorwaschzone + Waschzone, Bleche

Illustration 21682

Utgåva
Edition
Ausgabe
6

Månad
Month
Monat
08

År
Year
Jahr
2007

Pos.	Antal Quantity Anzahl	Art.nr Art. no Art. Nr	Benämning	Description	Bezeichnung	Anm. Notes Anm.
	[[[600 mm 900 mm 1400 mm			
1	1 - - - 1 - - - 1	428 18 06-00 ST0 26 13-00 ST0 25 18-00	Lucka kpl. Lucka kpl. Lucka kpl.	Door cpl. Door cpl. Door cpl.	Tür kpl. Tür kpl. Tür kpl.	
2	2 2 2	490 15 16-00	Gardin fäste	Curtain attachment	Vorhangbefestigung	
3	1 1 1	490 15 11-00	Gardin	Curtain	Vorhang	
4	1 1 1	482 76 03-01	Gardinaxel	Curtain shaft	Vorhangachse	
5	2 2 2	ST0 28 06-00	Handtag distans	Handle distance	Handgrif distanz	
6	2 2 2	514 75 40-00	Plast mutter	Plastic nut	Plast mutter	
7	1 1 1	547 73 40-00	Handtag	Handle	Handgrif	
8	1 - - - 1 - - - 1 - - 1	428 18 23-00 ST0 26 16-00 ST0 25 20-00 ST0 25 20-01	Lucklist Lucklist Lucklist Lucklist	Strip Strip Strip Strip	Leiste Leiste Leiste Leiste	1). 2).
9	2 2 2 2 2 2	481 99 27-03 481 99 27-01	Fäste Fäste	Attachement Attachement	Befestigung Befestigung	3). 4).
10	x x x	482 15 17-00	Isolerskiva	Insulation	Isolierung	
11	1 1 1 1 1 1	ST0 28 15-00 ST0 28 14-00	Front Front	Front Front	Vorderseite Vorderseite	1). 3). 1). 5).
	1 1 1 1 1 1	ST0 28 14-00 ST0 28 15-00	Front Front	Front Front	Vorderseite Vorderseite	2). 3). 2). 5).
12	2 2 2	ST0 27 96-00	Glidlist	Slide strip	Gleitprofil	
13	1 1 1 2 2 2 - 3 3	ST0 28 13-00 ST0 28 13-00 ST0 28 13-00	Front Front Front	Front Front Front	Vorderseite Vorderseite Vorderseite	4). WTF2 4). WTF3 4). WTF4
14	1 - - - 1 - - - 1	ST0 28 21-00 ST0 28 22-00 ST0 25 55-00	Frontplåt Frontplåt Frontplåt	Front panel Front panel Front panel	Frontblech Frontblech Frontblech	
15	2 2 2	855 64 90-00	Ben	Leg	Bein	
16	1 1 1	87 79 50-206	Kabelkanal	Canal passage	Kablekanal	0,9 m
17	1 1 1	552 21 30-00	Klämma	Clamp	Klemme	
18	1 1 1	482 76 78-00	Spolarmsstöd	Spraying arm support	Spularmstütze	
19	- - -	87 33 03-240	Packning	Gasket	Dichtung	
20	1 - - 1 1 1 1 1 -	ST0 30 20-00 482 71 73-00 ST0 36 90-00	Stänkplåt Stänkplåt Stänkplåt	Splasher Splasher Splasher	Spritzblech Spritzblech Spritzblech	3). 4). 8).
21	1 1 - - - 1	ST0 30 21-00 482 71 74-00	Stänkplåt Stänkplåt	Splasher Splasher	Spritzblech Spritzblech	

1). Vänstermatad
Left feeded
Links Richtung

2). Högermatad
Right feeded
Rechts Richtung

3). Anslutning: Inmatning - Disktank
Connection: Load section - Wash tank
Anschluss: Zulaufstrecke - Spültank

4). Anslutning: Disktank - Disktank
Connection: Wash tank - Wash tank
Anschluss: Spültank - Spültank

5). Anslutning: Slutspolningstank - Torkzon
Connection: Final rinsing tank - Drying zone
Anschluss: Nachspültank - Trockenzone

6). Med ESD
With ESD
Mit ESD

7). Utan ESD
Without ESD
Ohne ESD

8). Top(A) Fördisktank
Pre-wash tank
Vorspültank

Fet stil = Ändring
Bold print = Change
Fettdruck = Änderung

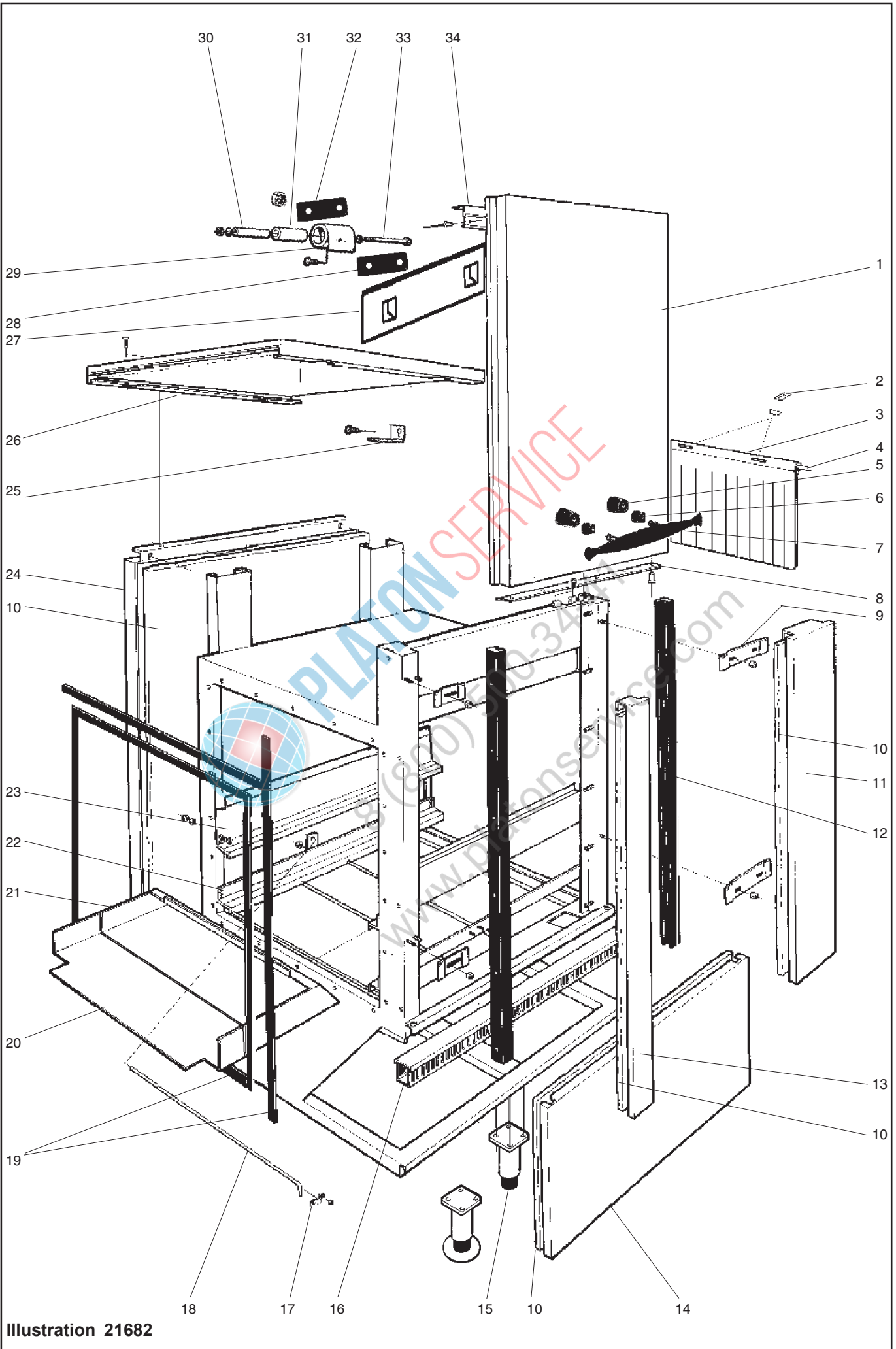

Illustration 21682

Fördisktank + disktank, plåtar
Prewash tank + wash tank, plates
Vorwaschzone + Waschzone, Bleche

Illustration 21682

Utgåva
Edition
Ausgabe
6

Månad
Month
Monat
08

År
Year
Jahr
2007

Pos.	Antal Quantity Anzahl	Art.nr Art. no Art. Nr	Benämning	Description	Bezeichnung	Anm. Notes Anm.
	[600 mm			
	[900 mm			
	[1400 mm			
22	1 - -	428 18 19-00	Bandgejd nedre	Slide Lower	Führungsleiste	WTF2 L=4500
	- 1 -	428 18 19-01	Bandgejd nedre	Slide Lower	Führungsleiste	WTF2 L=4800
	1 - -	428 18 19-04	Bandgejd nedre	Slide Lower	Führungsleiste	WTF3
	- 1 -	428 18 19-01	Bandgejd nedre	Slide Lower	Führungsleiste	WTF3 L=5800
	- 1 -	428 18 19-03	Bandgejd nedre	Slide Lower	Führungsleiste	WTF3 L=6100
	- 1 -	428 18 19-01	Bandgejd nedre	Slide Lower	Führungsleiste	WTF4 L=7400
	- 1 -	428 18 19-02	Bandgejd nedre	Slide Lower	Führungsleiste	WTF4 L=7400
23	1 - -	428 18 16-00	Bandgejd övre	Slide upper	Führungsleiste	WTF2 L=4500
	- 1 -	428 18 16-01	Bandgejd övre	Slide upper	Führungsleiste	WTF2 L=4800
	1 - -	428 18 16-04	Bandgejd övre	Slide upper	Führungsleiste	WTF3
	- 1 -	428 18 16-01	Bandgejd övre	Slide upper	Führungsleiste	WTF3 L=5800
	- 1 -	428 18 16-03	Bandgejd övre	Slide upper	Führungsleiste	WTF3 L=6100
	- 1 -	428 18 16-01	Bandgejd övre	Slide upper	Führungsleiste	WTF4 L=7400
	- 1 -	428 18 16-02	Bandgejd övre	Slide upper	Führungsleiste	WTF4 L=7400
24	1 - -	ST0 28 10-00	Baksida	Rear plate	Rückblech	
	- 1 -	ST0 28 11-00	Baksida	Rear plate	Rückblech	
	- - 2	ST0 25 56-00	Baksida	Rear plate	Rückblech	
25	1 1 1	428 18 07-00	Luckstopp	Door stop	Türstopp	
26	1 - -	ST0 28 16-00	Tak	Outer Roof	Oberseite	
	- 1 -	ST0 28 17-00	Tak	Outer Roof	Oberseite	
	- - 1	ST0 26 99-00	Tak	Outer Roof	Oberseite	1). 6).
	- - 1	ST0 26 99-01	Tak	Outer Roof	Oberseite	2). 6).
	- - 1	ST0 31 43-00	Tak	Outer Roof	Oberseite	1). 7).
	- - 1	ST0 31 43-01	Tak	Outer Roof	Oberseite	2). 7).
27	2 - -	ST0 28 12-00	Fäste	Attachment	Befestigung	
	- 1 -	ST0 43 72-00	Balk	Beam	Balken	
	- - 1	ST0 49 94-00	Balk	Beam	Balken	
28	2 3 4	ST0 28 19-00	Avstrykare inner	Guide, inner	Führung innen	
29	1 1 1	482 25 28-03	Luckfjäder	Door spring	Klappenfeder	
30	2 3 4	478 56 10-01	Distans	Spacerr	Distanz	
31	2 3 4	482 25 27-00	Rulle	Pully	Rolle	
32	2 3 4	ST0 28 20-00	Avstrykare ytter	Guide, outer	Führung, aussen	
33	2 3 4	725 24 65-45	Skruv	Screw	Schraube	8X70 RFR/SS
34	1 - -	428 18 12-00	Tätn.profil	Sealing profile	Dichtungsprofil	
	1 - -	428 18 24-00	Tätn.profil	Sealing profile	Dichtungsprofil	
	- 1 -	ST0 26 15-00	Tätn.profil	Sealing profile	Dichtungsprofil	
	- 1 -	ST0 26 14-00	Tätn.profil	Sealing profile	Dichtungsprofil	
	- - 1	ST0 25 53-00	Tätn.profil	Sealing profile	Dichtungsprofil	
	- - 1	ST0 25 54-00	Tätn.profil	Sealing profile	Dichtungsprofil	

1). Vänstermatad
Left feeded
Links Richtung

2). Högermatad
Right feeded
Rechts Richtung

3). Anslutning: Inmatning - Disktank
Connection: Load section - Wash tank
Anschluss: Zulaufstrecke - Spültank

4). Anslutning: Disktank - Disktank
Connection: Wash tank - Wash tank
Anschluss: Spültank - Spültank

5). Anslutning: Slutspolningstank - Torkzon
Connection: Final rinsing tank - Drying zone
Anschluss: Nachspültank - Trockenzone

6). Med ESD
With ESD
Mit ESD

7). Utan ESD
Without ESD
Ohne ESD

8). Top(A) Fördisktank
Pre-wash tank
Vorspültank

Fet stil = Ändring
Bold print = Change
Fettdruck = Änderung

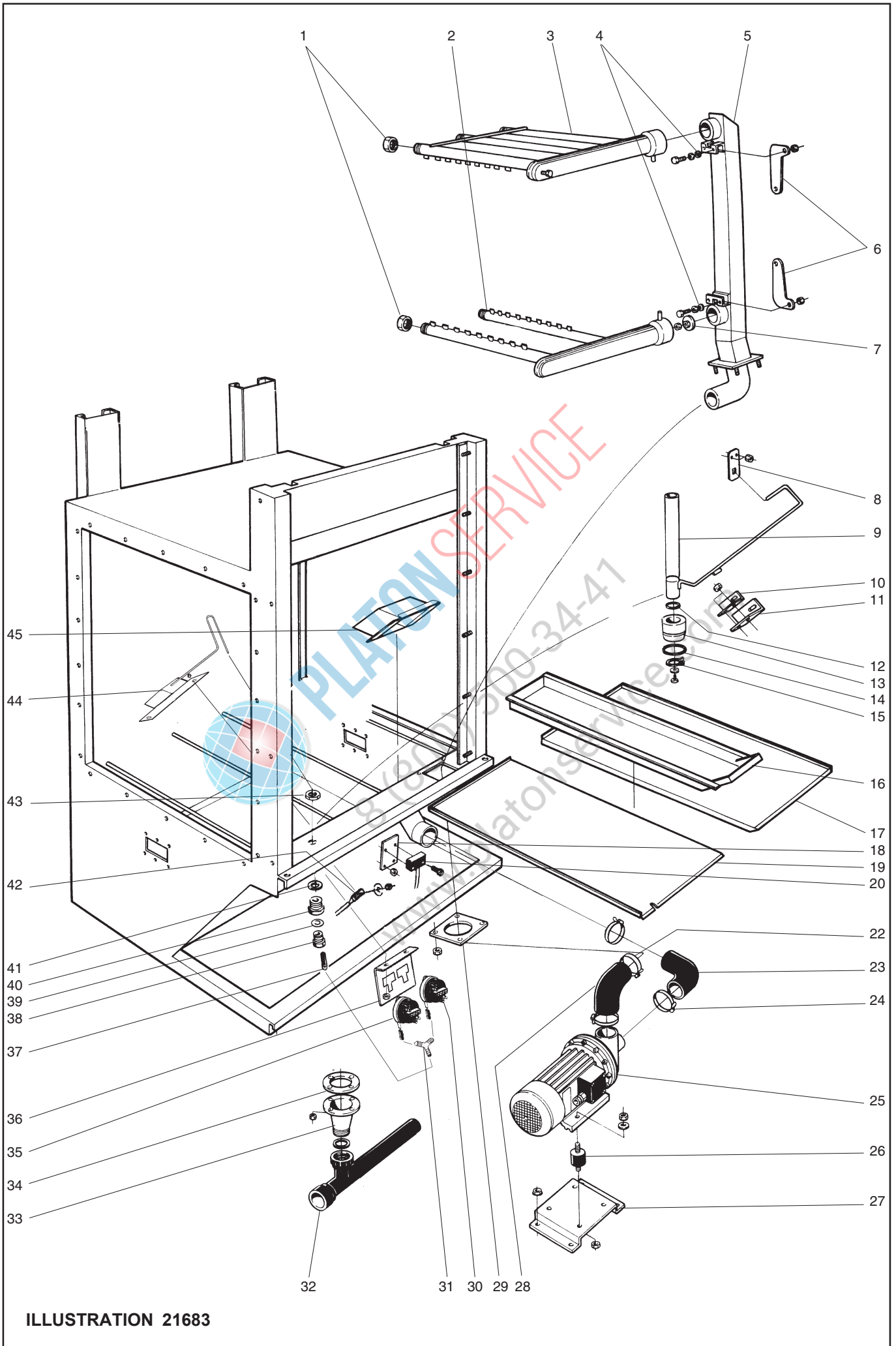

ILLUSTRATION 21683

Avlopp och disksystem L=600 Drain and wash system L=600 Ablauf und Spülsystem L=600			Illustration 21683			Utgåva Edition Ausgabe 3	Månad Month Monat 11	År Year Jahr 2004
Pos.	Antal Quantity Anzahl	Art.nr Art. no Art. Nr	Benämning	Description	Bezeichnung	Anm. Notes Anm.		
1	5	741 61 16-24	Huv	Cover	Haube			
2	1	ST0 24 98-00	Spolarm nedre	Spraying arm lower	Spülarm			
3	1	ST0 24 97-00	Spolarm övre	Spraying arm upper	Spülarm	1).		
	1	ST0 28 23-00	Spolarm övre	Spraying arm upper	Spülarm	2).		
4	3	57 03 98-06	Packning	Gasket	Dichtung			
5	1	499 74 85-00	Stamrör	Main conduit	Stammleitung			
6	2	490 14 45-00	Låshandtag	Lock handle	Schlosshandgriff			
7	1	482 37 78-00	Strypbricka	Reducing washer	Drosselscheibe			
8	1	482 78 27-00	Styrplåt	Guide plate	Führungsplatte			
9	1	482 78 82-00	Avloppsstängning	Drain closer	Abflussabspernung			
10	1	482 78 26-00	Styrvinkel, vänster	Angular guide, left	Winkelführung, links			
11	1	482 78 25-00	Styrvinkel, höger	Angular guide, right	Winkelführung, rechts			
12	1	740 44 08-14	O-ring	O-ring	O-Ring			
13	1	475 77 83-00	Bottenplugg	Bottom plug	Bodenpfropfen			
14	1	475 81 24-02	O-ring	O-ring	O-Ring			
15	1	735 31 30-07	Spårring	C-clamp	Seegerring			
16	1	482 74 68-00	Silkorg	Strainer box	Siebkasten			
17	1	ST0 26 01-00	Silplåt	Strainer plate	Siebplatte			
18	1	481 99 42-00	Fäste	Attachment	Befestigung			
19	1	ST0 26 02-00	Silplåt	Strainer plate	Siebplatte			
20	1	476 06 64-00	Magnetbrytare	Magnetic switch	Magnetausschalter			
22	4	736 28 40-51	Slangklämma	Hose clamp	Schlauchklemme	D=65		
23	1	482 42 08-01	Slang	Hose	Schlauch			
24	2	736 28 43-51	Slangklämma	Hose clamp	Schlauchklemme	D= 75		
25	1	482 50 91-00	Pump	Pump	Pumpe	3).	230 / 400V, 50Hz	
	1	482 50 91-01	Pump	Pump	Pumpe	3).	220-254 / 400-440V, 60Hz	
	1	482 50 91-02	Pump	Pump	Pumpe	200V, 50Hz		
	1	482 50 91-03	Pump	Pump	Pumpe	200V, 60Hz		
	1	482 50 91-15	Pumphjul	Impeller	Pumpenrad	50 Hz		
	1	482 50 91-17	Pumphjul	Impeller	Pumpenrad	60 Hz		
	1	482 50 91-13	Tätning	Gasket	Dichtung			
	1	482 50 91-11	Fläkthjul	Fanwheel	Gebläserad			
	1	499 84 91-00	Pump	Pump	Pumpe	4).	230 / 400V, 50Hz	
26	4	463 97 78-06	Dämpare	Absorber	Vibrationsdämpfer	3).		
	4	463 97 78-08	Dämpare	Absorber	Vibrationsdämpfer	4).		
27	1	499 76 66-00	Pumpkonsol	Pump bucket	Pumpenkonsole	3).		
28	1	482 52 56-00	Slang	Hose	Schlauch			
29	1	482 34 82-00	Fläns	Flange	Flansche			
30	1	ST0 28 94-00	Nivåbrytare	Level switch	Standshalter	55/35		
31	1	ST0 31 21-00	Y-koppling	Y- connection	Y- kopplung			
32	1	ST0 28 72-01	Avloppsrör	Drain pipe	Ablaufrohr			
33	1	475 77 84-00	Avloppsstos	Drain pipe connection	Ablaufstutzen			
34	1	477 73 94-00	Packning	Gasket	Dichtung			

Fet stil = Ändring
 Bold print = Change
 Fettdruck = Änderung

- 1). Vänstermatad maskin / Left hand side fed machine / Maschine mit Linkszuführung
 2). Högermatad maskin / Right hand side fed machine / Maschine mit Rechtszuführung
 3). **Basic(C) & Medium(B)**
 4). **Top(A)**

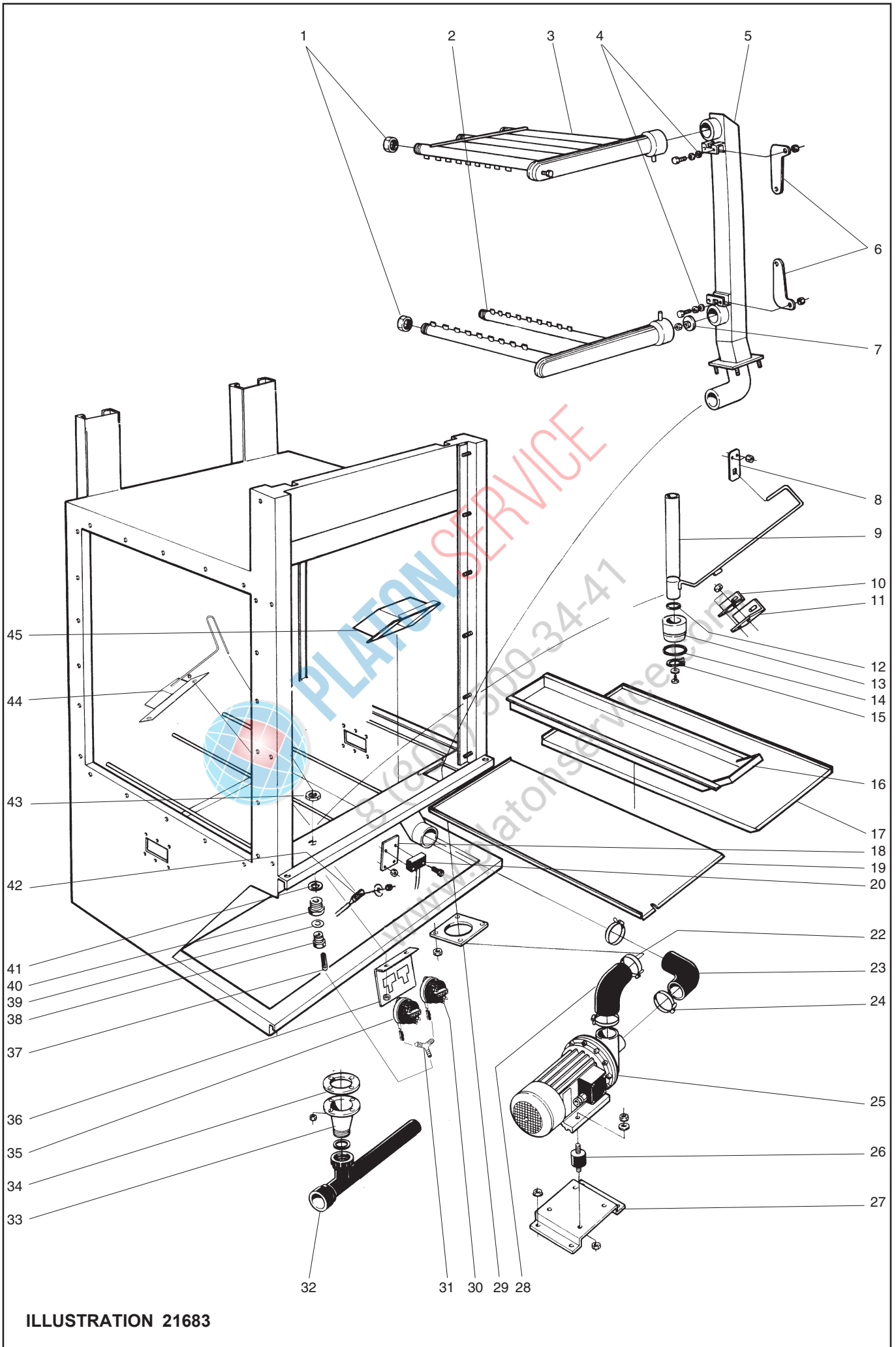

ILLUSTRATION 21683

Avlopp och disksystem L=600
 Drain and wash system L=600
 Ablauf und Spülsystem L=600

Illustration 21683

Utgåva
 Edition
 Ausgabe
 3

Månad
 Month
 Monat
 11

År
 Year
 Jahr
 2004

Pos.	Antal Quantity Anzahl	Art.nr Art. no Art. Nr	Benämning	Description	Bezeichnung	Anm. Notes Anm.
35	1	ST0 28 93-00	Nivåbrytare	Level switch	Standsschalter	40/15
36	1	ST0 28 91-00	Fästplåt nivåbrytare	Attachment, level switch	Befestigung	
37	X	87 75 25-102	Gummislang	Rubber hose	Gummischlauch	1/4"
38	1	478 04 46-00	Nippel	Nipple	Nippel	
39	1	740 43 03-14	O-ring	O-ring	O-ring	
40	1	ST0 31 22-00	Bulpnippel	Bulb nipple	Bulbnippel	
41	1	552 21 10-01	Packning	Gasket	Dichtung	
42	1	478 08 64-01	Termistor	Thermistor	Thermistor	
43	1	741 11 10-24	Rörmutter	Pipe nut	Rohrmutter	
44	1	ST0 28 33-00	Luftklocka	Air tube	Luftrohr	
45	1	491 39 65-00	Pumpsil	Pump strainer	Pumpensieb	



PLATON SERVICE

8 (800) 500-34-47

www.platonservice.com

Fet stil = Ändring
 Bold print = Change
 Fettdruck = Änderung

- 1). Vänstermatad maskin / Left hand side fed machine / Maschine mit Linkszuführung
- 2). Högermatad maskin / Right hand side fed machine / Maschine mit Rechtszuführung
- 3). **Basic(C) & Medium(B)**
- 4). **Top(A)**

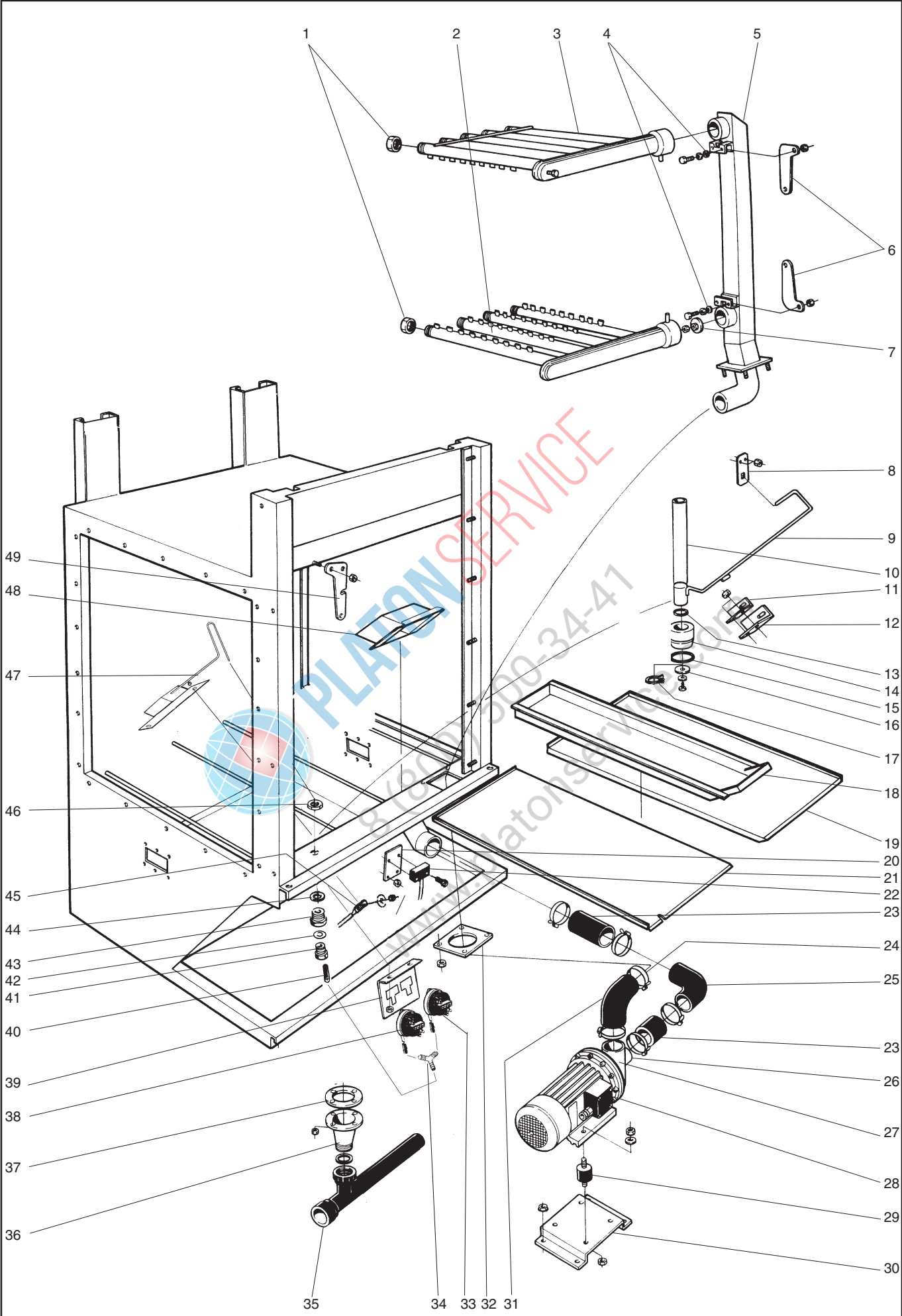

ILLUSTRATION 21684

Avlopp och disksystem L=900 Drain and wash system L=900 Ablauf und Spülsystem L=900			Illustration 21684			Utgåva Edition Ausgabe 3	Månad Month Monat 08	År Year Jahr 2007
Pos.	Antal Quantity Anzahl	Art.nr Art. no Art. Nr	Benämning	Description	Bezeichnung	Anm. Notes Anm.		
	[Fördisk	Prewash	Vorwaschzone			
	[Kemdisk	power rinse	Waschzone,			
1	9	9 741 61 16-24	Huv	Cover	Haube			
2	1	1 482 78 98-00	Spolarm nedre	Spraying arm lower	Spülarm			
3	1	1 482 78 96-00	Spolarm övre	Spraying arm upper	Spülarm	1).		
	1	1 482 78 97-00	Spolarm övre	Spraying arm upper	Spülarm	2).		
4	3	3 57 03 98-06	Packning	Gasket	Dichtung			
5	1	1 ST0 59 93-00	Stamrör	Main conduit	Stammlleitung			
6	2	2 490 14 45-00	Låshandtag	Lock handle	Schlosshandgriff			
7	1	1 482 37 78-00	Strypbricka	Reducing washer	Drosselscheibe			
8	1	1 482 78 27-00	Styrplåt	Guide plate	Führungsplatte			
9	-	1 482 78 81-00	Avloppsstängning	Drain closer	Abflussabspernung			
10	1	- 482 78 82-00	Avloppsstängning	Drain closer	Abflussabspernung			
11	1	1 482 78 26-00	Styrvinkel, vänster	Angular guide, left	Winkelführung, links			
12	1	1 482 78 25-00	Styrvinkel, höger	Angular guide, right	Winkelführung, rechts			
13	1	1 740 44 08-14	O-ring	O-ring	O-Ring			
14	1	1 475 77 83-00	Bottenplugg	Bottom plug	Bodenpfropfen			
15	1	1 475 81 24-02	O-ring	O-ring	O-Ring			
16	-	1 53 92 88-32	Bricka	Washer	Scheibe			
17	1	- 735 31 30-07	Spårring	C-clamp	Seegerring			
18	1	1 482 74 68-00	Silkorg	Strainer box	Siebkasten			
19	1	1 482 74 63-00	Silplåt	Strainer plate	Siebplatte			
20	1	1 481 99 42-00	Fäste	Attachment	Befestigung			
21	1	1 482 74 64-00	Silplåt	Strainer plate	Siebplatte			
22	1	1 476 06 64-00	Magnetbrytare	Magnetic switch	Magnetausschalter			
23	2	2 477 92 11-00	Slang	Hose	Schlauch	3).		
	1	1 ST0 32 52-00	Slang	Hose	Schlauch	4).		
24	4	4 736 28 43-51	Slangklämma	Hose clamp	Schlauchklemme	D=75		
25	1	1 482 59 74-00	Slang	Hose	Schlauch			
26	1	1 499 84 28-01	Anslutningsdel Insug	Connection suction	Anschluss einsaugen	2"		4).
27	1	1 499 86 59-00	Anslutning	Connection, suction	Anschluss, einsaugen	1 1/2"		4).
28	1	1 482 77 83-00	Pump	Pump	Pumpe	230 / 400V, 50Hz		3).
	1	1 482 77 83-01	Pump	Pump	Pumpe	220-254 /400-440V, 60Hz		3).
	1	1 482 77 83-02	Pump	Pump	Pumpe	200V, 50Hz		3).
	1	1 482 77 83-03	Pump	Pump	Pumpe	200V, 60Hz		3).
	1	1 482 77 83-15	Pumphjul	Impeller	Pumpenrad	50 Hz		3).
	1	1 482 77 83-17	Pumphjul	Impeller	Pumpenrad	60 Hz		3).
	1	1 482 77 83-13	Tätning	Gasket	Dichtung	3).		
	1	1 482 77 83-11	Fläkthjul	Fanwheel	Gebbläserad	3).		
	1	1 499 83 79-00	Pump	Pump	Pumpe	230 / 400V, 50Hz		4).
	1	1 499 83 79-60	Pump	Pump	Pumpe	230 / 400V, 60Hz		4).
29	4	4 463 97 78-08	Dämpare	Absorber	Vibrationsdämpfer	3).		
	6	6 463 97 78-08	Dämpare	Absorber	Vibrationsdämpfer	4).		
30	1	1 482 78 09-00	Pumpkonsol	Pump basket	Pumpenkonsole	3).		
	1	1 ST0 32 91-00	Pumpkonsol	Pump basket	Pumpenkonsole	4).		

Fet stil = Ändring
Bold print = Change
Fettdruck = Änderung

- 1). Vänstermatad maskin / Left hand side fed machine / Maschine mit Linkszuführung
- 2). Högermatad maskin / Right hand side fed machine / Maschine mit Rechtszuführung
- 3). Basic/Medium
- 4). Top

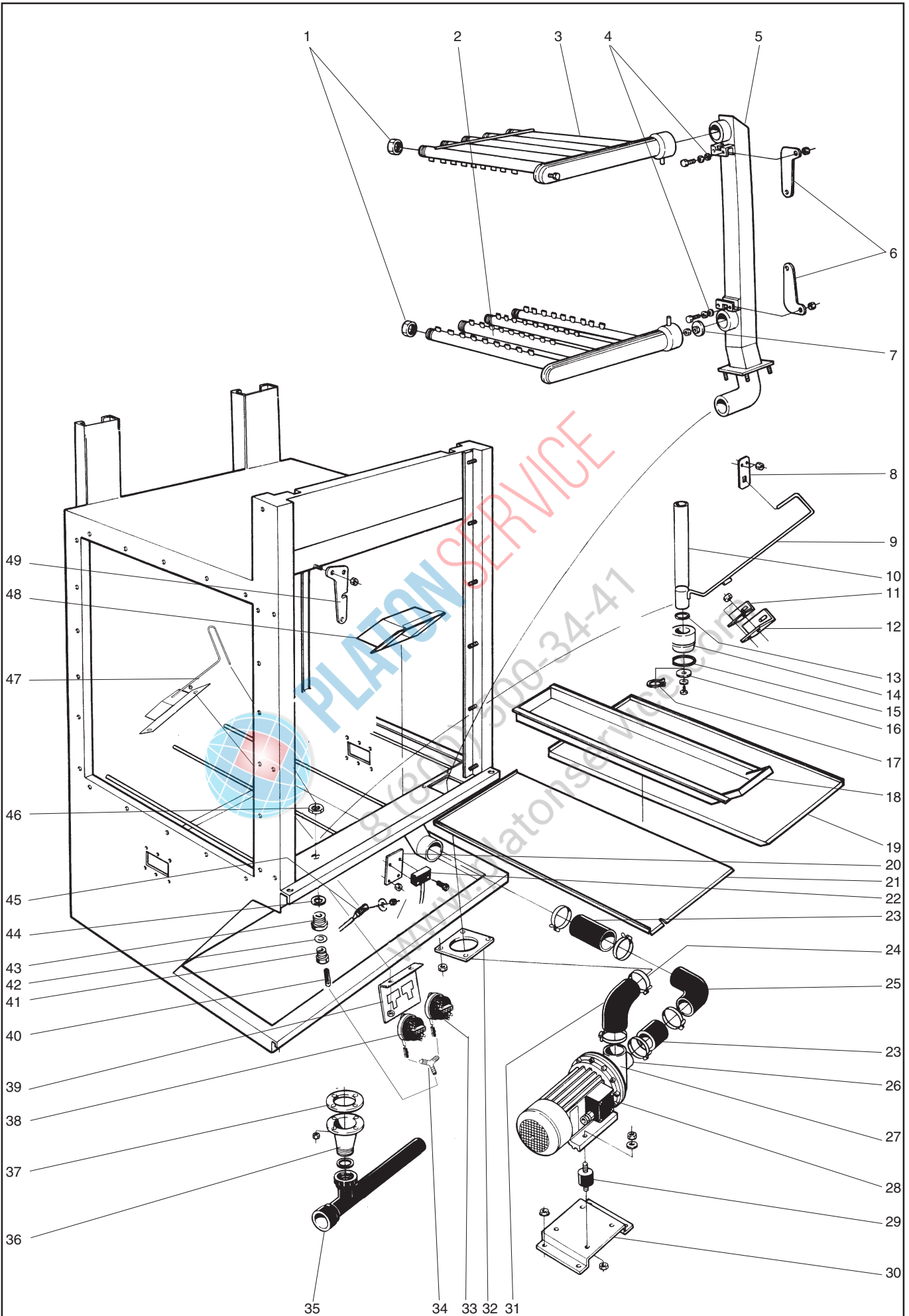

ILLUSTRATION 21684

Avlopp och disksystem L=900 Drain and wash system L=900 Ablauf und Spülsystem L=900			Illustration 21684			Utgåva Edition Ausgabe 3	Månad Month Monat 08	År Year Jahr 2007
Pos.	Antal Quantity Anzahl	Art.nr Art. no Art. Nr	Benämning	Description	Bezeichnung	Anm. Notes Anm.		
	[Fördisk	Prewash	Vorwaschzone			
	[Kemdisk	power rinse	Waschzone			
31	1	482 42 07-01	Slang	Hose	Schlauch			
32	1	482 34 82-00	Fläns	Flange	Flansche			
33	1	ST0 28 93-00	Nivåbrytare	Level switch	Standswitch	40/15		
34	1	ST0 31 21-00	Y-koppling	Y-connection	Y-kopplung			
35	1	ST0 28 72-00	Avloppsrör	Drain pipe	Ablaufrohr			
36	1	475 77 84-00	Avloppsstos	Drain pipe connection	Ablaufstutzen			
37	1	477 73 94-00	Packning	Gasket	Dichtung			
38	1	ST0 28 94-00	Nivåbrytare	Level switch	Standswitch	55/35		
39	1	ST0 28 91-00	Fästplåt nivåbrytare	Attachment, level switch	Befestigung			
40	X	87 75 25-102	Gummislang	Rubber hose	Gummischlauch			
41	1	478 04 46-00	Nippel	Nipple	Nippel			
42	1	740 43 03-14	O-ring	O-ring	O-ring			
43	1	ST0 31 22-00	Bulbnippel	Bulb nipple	Bulbnippel			
44	1	552 21 10-01	Packning	Gasket	Packung			
45	1	478 08 64-01	Termistor	Thermistor	Thermistor			
46	1	741 11 10-24	Rörmutter	Pipe nut	Rohrmutter			
47	1	ST0 28 33-00	Luftklocka	Air tube	Luftrohr			
48	1	491 39 65-00	Pumpsil	Pump strainer	Pumpensieb			
49	1	490 14 45-01	Låshandtag	Lock handle	Schlosshandgriff			



PLATON SERVICE
8 (800) 500-34-47
www.platonservice.com

Fet stil = Ändring
Bold print = Change
Fettdruck = Änderung

- 1). Vänstermatad maskin / Left hand side fed machine / Maschine mit Linkszuführung
- 2). Högermatad maskin / Right hand side fed machine / Maschine mit Rechtszuführung
- 3). Basic/Medium
- 4). Top

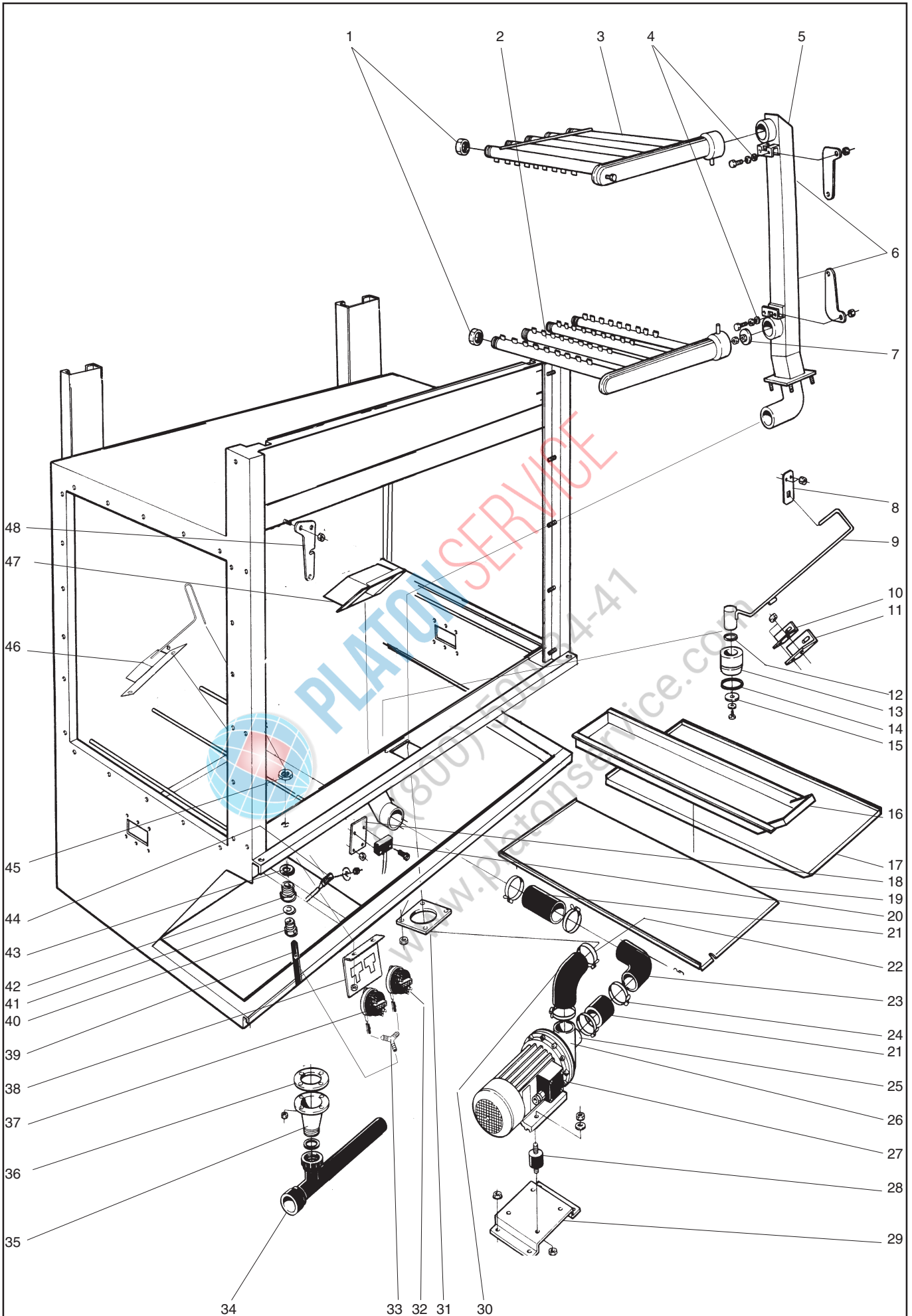

ILLUSTRATION 216 85

Avlopp och disksystem L=1400 Drain and wash system L=1400 Ablauf und Spülsystem L=1400			Illustration 21685			Utgåva Edition Ausgabe 2	Månad Month Monat 01	År Year Jahr 2005
Pos.	Antal Quantity Anzahl	Art.nr Art. no Art. Nr	Benämning	Description	Bezeichnung	Anm. Notes Anm.		
1	9	741 61 16-24	Huv	Cover	Haube			
2	1	482 78 98-00	Spolarm nedre	Spraying arm lower	Spülarm			
3	1	482 78 96-00	Spolarm övre	Spraying arm upper	Spülarm	1).		
	1	482 78 97-00	Spolarm övre	Spraying arm upper	Spülarm	2).		
4	3	57 03 98-06	Packning	Gasket	Dichtung			
5	1	482 78 18-00	Stamrör	Main conduit	Stammlleitung	3).		
	1	ST0 32 51-00	Stamrör	Main conduit	Stammlleitung	4).		
6	2	490 14 45-00	Låshandtag	Lock handle	Schlosshandgriff			
7	1	482 37 78-00	Strypbricka	Reducing washer	Drosselscheibe			
8	1	482 78 27-00	Styrplåt	Guide plate	Führungsplatte			
9	1	482 78 81-00	Avloppsstängning	Drain closer	Abflussabspernung			
10	1	482 78 26-00	Styrvinkel, vänster	Angular guide, left	Winkelführung, links			
11	1	482 78 25-00	Styrvinkel, höger	Angular guide, right	Winkelführung, rechts			
12	1	740 44 08-14	O-ring	O-ring	O-Ring			
13	1	475 77 83-00	Bottenplugg	Bottom plug	Bodenpfropfen			
14	1	475 81 24-02	O-ring	O-ring	O-Ring			
15	1	53 92 88-32	Bricka	Washer	Scheibe			
16	1	482 74 68-00	Silkorg	Strainer box	Siebkasten			
17	1	482 74 63-00	Silplåt	Strainer plate	Siebplatte			
18	1	481 99 42-00	Fäste	Attachment	Befestigung			
19	1	482 74 64-00	Silplåt	Strainer plate	Siebplatte			
20	1	476 06 64-00	Magnetbrytare	Magnetic switch	Magnetausschalter			
21	2	477 92 11-00	Slang	Hose	Schlauch	3).		
	1	ST0 32 52-00	Slang	Hose	Schlauch	4).		
22	2	736 28 40-51	Slangklämma	Hose clamp	Schlauchklemme	D=65		
23	1	482 59 74-00	Slang	Hose	Schlauch			
24	4	736 28 43-51	Slangklämma	Hose clamp	Schlauchklemme	D=75		
25	1	499 84 28-01	Anslutningsdel Insug	Connection suction	Anschluss einsaugen	2"		4).
26	1	499 86 59-00	Anslutningsdel Insug	Connection suction	Anschluss einsaugen	1 1/2"		4).
27	1	482 77 83-00	Pump	Pump	Pumpe	230 / 400V, 50Hz		3).
	1	482 77 83-01	Pump	Pump	Pumpe	220-254 /400-440V, 60Hz		3).
	1	482 77 83-02	Pump	Pump	Pumpe	200V, 50Hz		3).
	1	482 77 83-03	Pump	Pump	Pumpe	200V, 60Hz		3).
	1	482 77 83-15	Pumphjul	Impeller	Pumpenrad	50 Hz		3).
	1	482 77 83-17	Pumphjul	Impeller	Pumpenrad	60 Hz		3).
	1	482 77 83-13	Tätning	Gasket	Dichtung			3).
	1	482 77 83-11	Fläkthjul	Fanwheel	Gebbläserad			3).
	1	499 83 79-00	Pump	Pump	Pumpe	230 / 400V, 50Hz		4).
28	4	463 97 78-08	Dämpare	Absorber	Vibrationsdämpfer	3).		
	6	463 97 78-08	Dämpare	Absorber	Vibrationsdämpfer	4).		
29	1	482 78 09-01	Pumpkonsol	Pump bucket	Pumpenkonsole	3).		
	1	ST0 32 91-00	Pumpkonsol	Pump bucket	Pumpenkonsole	4).		
30	1	482 42 07-00	Slang	Hose	Schlauch			
31	1	482 34 82-00	Fläns	Flange	Flansche			

Fet stil = Ändring
Bold print = Change
Fettdruck = Änderung

- 1). Vänstermatad maskin / Left hand side fed machine / Maschine mit Linkszuführung
- 2). Högermatad maskin / Right hand side fed machine / Maschine mit Rechtszuführung
- 3). Basic/Medium
- 4). Top

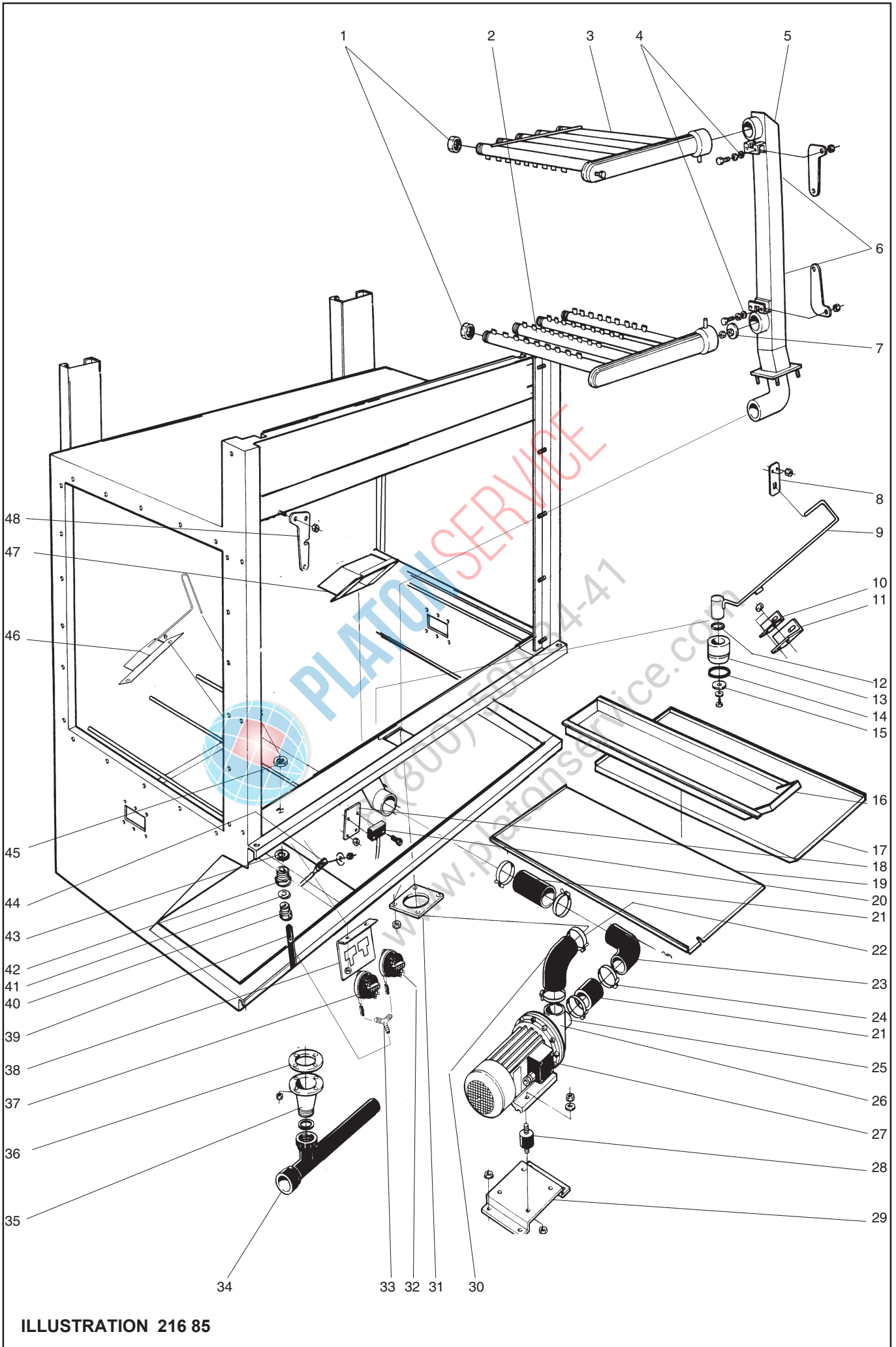

ILLUSTRATION 216 85

Avlopp och disksystem L=1400
 Drain and wash system L=1400
 Ablauf und Spülsystem L=1400

Illustration 21685

Utgåva
 Edition
 Ausgabe
 2

Månad
 Month
 Monat
 01

År
 Year
 Jahr
 2005

Pos.	Antal Quantity Anzahl	Art.nr Art. no Art. Nr	Benämning	Description	Bezeichnung	Anm. Notes Anm.
32	1	ST0 28 93-00	Nivåbrytare	Level switch	Standsschalter	40/15
33	1	ST0 31 21-00	Y-koppling	Y- connection	Y- kopplung	
34	1	ST0 28 72-00	Avloppsrör	Drain pipe	Ablaufrohr	
35	1	475 77 84-00	Avloppsstos	Drain pipe connection	Ablaufstutzen	55/35
36	1	477 73 94-00	Packning	Gasket	Dichtung	
37	1	ST0 28 94-00	Nivåbrytare	Level switch	Standsschalter	
38	1	ST0 28 91-00	Fästplåt nivåbrytare	Attachment, level switch	Befestigung	55/35
39	X	87 75 25-102	Gummislang	Rubber hose	Gummischlauch	
40	1	478 04 46-00	Nippel	Nipple	Nippel	55/35
41	1	740 43 03-14	O-ring	O-ring	O-ring	
42	1	ST0 31 22-00	Bulbnippel	Bulb nipple	Bulbnippel	55/35
43	1	552 21 10-01	Packning	Gasket	Packung	
44	1	478 08 64-01	Termistor	Thermistor	Thermistor	55/35
45	1	741 11 10-24	Rörmutter	Pipe nut	Rohrmutter	
46	1	ST0 28 33-00	Luftklocka	Air tube	Luftrohr	55/35
47	1	491 39 65-00	Pumpsil	Pump strainer	Pumpensieb	
48	1	490 14 45-01	Låshandtag	Lock handle	Schlosshandgriff	55/35



PLATON SERVICE
 8 (800) 500-34-47
 www.platonservice.com

Fet stil = Ändring
Bold print = Change
Fettdruck = Änderung

- 1). Vänstermatad maskin / Left hand side fed machine / Maschine mit Linkszuführung
- 2). Högermatad maskin / Right hand side fed machine / Maschine mit Rechtszuführung
- 3). Basic/Medium
- 4). Top

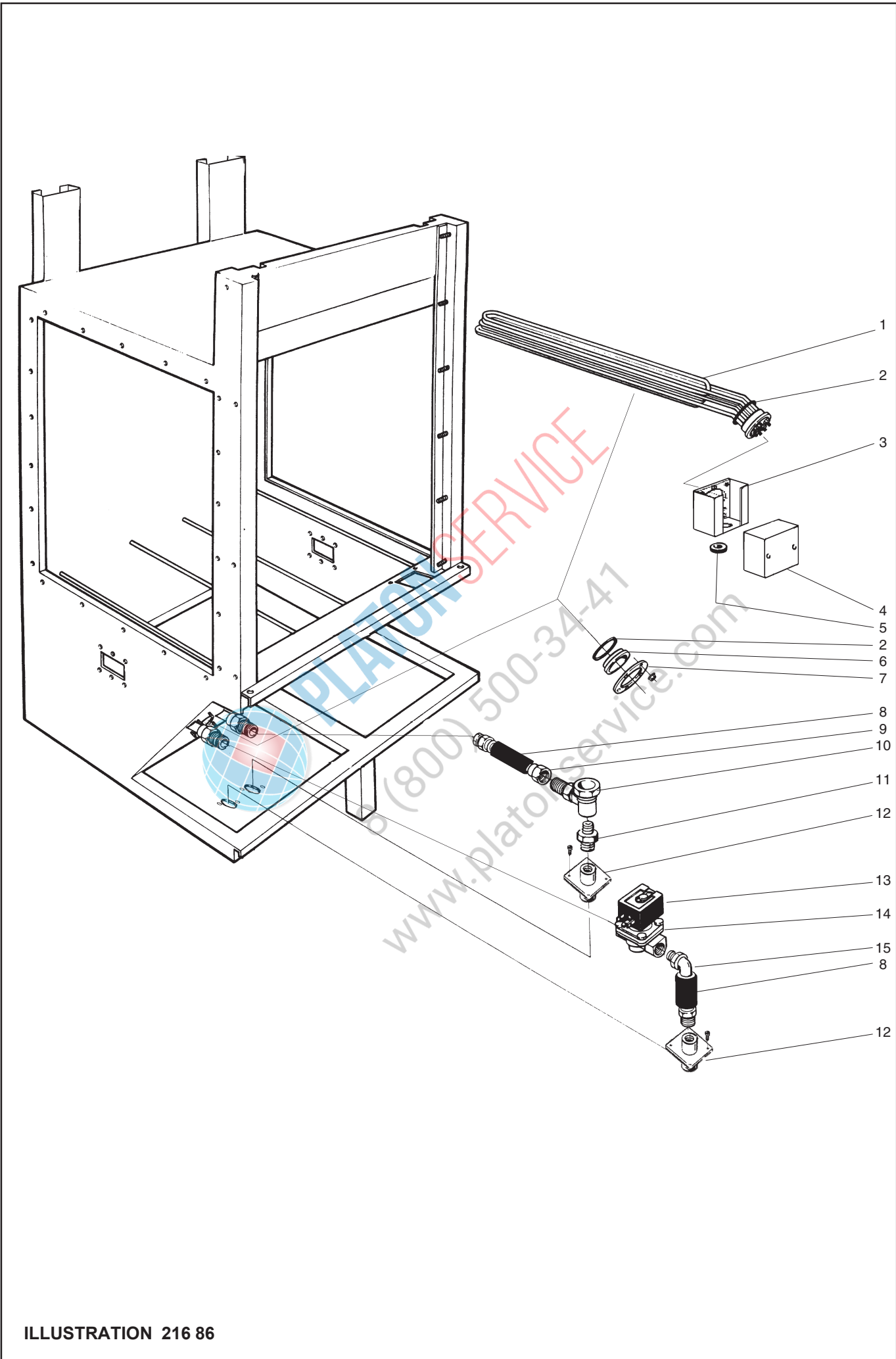

ILLUSTRATION 216 86

Uppvärmning Heating Beheizung			Illustration 21686			Utgåva Edition Ausgabe 3	Månad Month Monat 11	År Year Jahr 2004
Pos.	Antal Quantity Anzahl	Art.nr Art. no Art. Nr	Benämning	Description	Bezeichnung	Anm. Notes Anm.		
	[Eluppvärmd	El. heated	El. beheizt			
	[Ånguppvärmd	Steam heated	Dampfbeheizt			
1	1	482 74 89-00	Element 15 kW	Heating element 15 kW	Heizkörper 15 kW	230 / 400V	1).	
	1	482 74 89-01	Element 12 kW	Heating element 12 kW	Heizkörper 12 kW	230 / 400V	2).	
2	1	740 48 31-05	O-ring	O-ring	O-Ring			
3	1	ST0 31 18-00	Lock, elementkåpa	Lid, element casing	Deckel, elementhaube			1).
4	1	ST0 31 17-00	Elementkåpa	Element casing	Elementhaube			1).
5	1	762 12 32-00	Genomföring	Inlet	Durchführung	D=15		
6	-	482 47 94-00	Lock	Lid	Deckel			3).
7	-	478 08 59-00	Elementfläns	Heating element flange	Heizkörperflansch			3).
8	-	552 00 08-00	Isoleringslang	Isolation hose	Isolierschlauch	D22x36		
9	-	ST0 34 96-00	Rör kpl.	Pipe cpl.	Rohr kpl			
10	-	63 79 74-01	Ångfälla	Steam trap	Kondensfalle			
11	-	741 31 15-22	Nippel	Nipple	Nippel	3/4"		
12	-	ST0 34 94-00	Fäste					
13	-	463 97 00-00	Kabelhuvud	Cable terminal	Kabelanschluß			
14	-	482 17 40-03	Magnetventil	Solenoid valve	Magnetventil	50 Hz		
	-	482 17 40-06	Magnetventil	Solenoid valve	Magnetventil	60 Hz		
15	-	ST0 34 95-00	Rör kpl.	Pipe cpl.	Rohr kpl			



PLATON SERVICE
8 (800) 500-34-47
www.platonservice.com

Fet stil = Ändring
Bold print = Change
Fettdruck = Änderung

1). Kemdisktank
2). WTF4, kemdisktank 2
3). Fördisktank

Chemical wash tank
WTF4, chemical wash tank
Prewash tank

Hauptwaschzone
2 WTF4, Hauptwaschzone 2
Vorwaschzone

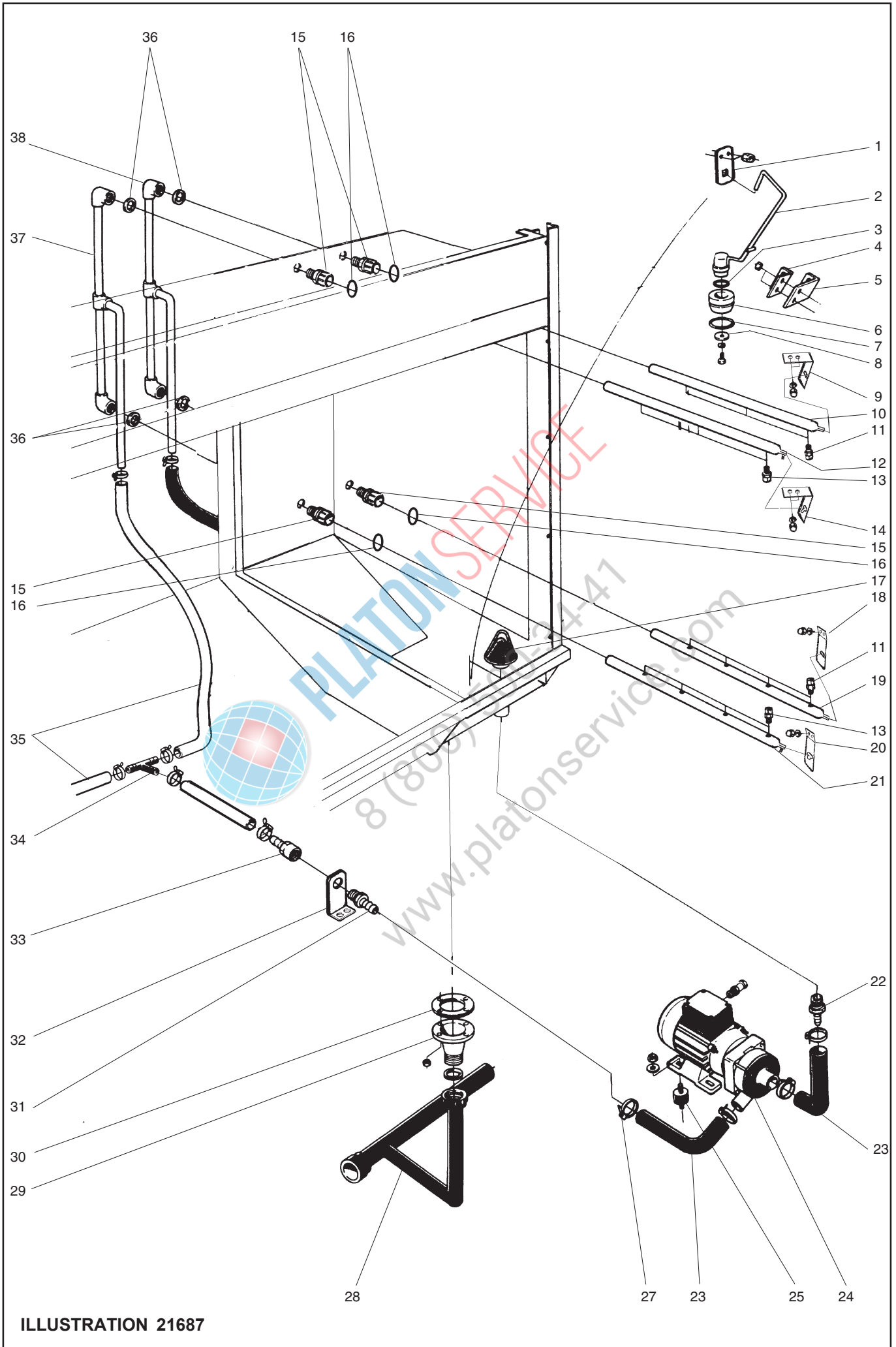

ILLUSTRATION 21687

Slutspolningstank, spolsystem Final rinse tank, wash system Nachspültank, Spülsystem			Illustration 21687			Utgåva Edition Ausgabe 6	Månad Month Monat 08	År Year Jahr 2007
Pos.	Antal Quantity Anzahl	Art.nr Art. no Art. Nr	Benämning	Description	Bezeichnung	Anm. Notes Anm.		
1	1	482 78 27-00	Styrplåt	Guide plate	Führungsplatte			
2	1	482 78 91-00	Avloppsstängning	Drain closer	Abflussabspernung			
3	1	740 44 08-14	O-ring	O-ring	O-Ring			
4	1	482 78 93-00	Styrvinkel, vänster	Angular guide , left	Winkelführung, links			
5	1	482 78 92-00	Styrvinkel, höger	Angular guide, right	Winkelführung, rechts			
6	1	475 77 83-00	Bottenplugg	Bottom plug	Bodenpfropfen			
7	1	475 81 24-02	O-ring	O-ring	O-Ring			
8	1	53 92 88-32	Bricka	Washer	Scheibe			
9	1	428 02 08-00	Spolrörsfjäder Övre	Spring upper	Feder oben			
10	1	428 02 11-01	Slutskölj.rör	Pipe	Rohr			
11	7	482 78 46-01	Munstycke	Nozzle	Düse			
12	1	428 02 11-04	Slutskölj.rör	Pipe	Rohr			
13	7	482 78 46-00	Munstycke	Nozzle	Düse			
14	1	428 02 08-01	Spolrörsfjäder Övre	Spring upper	Feder oben			
15	4	428 02 07-00	Snabbkoppling	Joint	Kupplung	1/2"-18		
16	4	740 43 15-14	O-ring	O-ring	O-ring	17,3X2,4 EPDM		
17	1	477 90 36-00	Finsil	Strainer	Sieb			
	1	482 42 79-00	Kedja	Chain	Ketten			
18	1	428 02 09-00	Spolrörsfjäder nedre	Spring Lower	Feder unter			
19	1	428 02 10-01	Slutskölj.rör kpl.	Pipe	Rohr			
20	1	428 02 09-01	Spolrörsfjäder nedre	Spring Lower	Feder unter			
21	1	428 02 10-03	Slutskölj.rör	Pipe	Rohr			
22	1	552 21 40-31	Slangnippel	Hose Nipple	Schlauchnippel			
23	2	478 08 71-00	Slang	Hose	Schlauch			
24	1	482 77 21-00	Pump	Pump	Pumpe	230 / 400V, 50 Hz		
	1	482 77 21-02	Pump	Pump	Pumpe	230 / 400V, 60 Hz		
		482 77 21-10	Pumphus	Pump housing	Pumpengehäuse			
		482 77 21-11	Packning	Gasket	Dichtung			
		482 77 21-12	Pumphjul	Impeller	Pumpenrad			
25	4	463 97 78-06	Dämpare	Absorber	Dämpfer			
27	4	736 28 28-51	Slangklämma	Hose clamp	Schlauchklemme	D=38		
28	1	ST0 28 73-00	Avlopp	Drain	Ablauf	1)		
	1	ST0 28 73-01	Avlopp	Drain	Ablauf	2)		
29	1	475 77 84-00	Avloppsstos	Drain Connection	Ablaufstutzen			
30		477 73 94-00	Packning	Gasket	Dichtung			
31	1	552 21 40-28	Slangnippel	Hose Nipple	Schlauchnippel	20x1"		
32	1	ST0 28 69-00	Fäste	Attachement	Befestigung			
33	1	552 21 59-00	Slangnippel	Hose Nipple	Schlauchnippel	1/2"-11/4"		
34	1	ST0 44 86-00	T-rör	T-tube	T-rohr	1/2"		
35	x	552 00 11-00	Slang	Hose	Schlauch			
36	4	552 21 10-03	Packning	Gasket	Dichtung			

Fet stil = Ändring

Bold print = Change

Fettdruck = Änderung

1). Vänstermatad , Left feeded, Links richtung

2). Högermatad , Right feeded, Rechts richtung

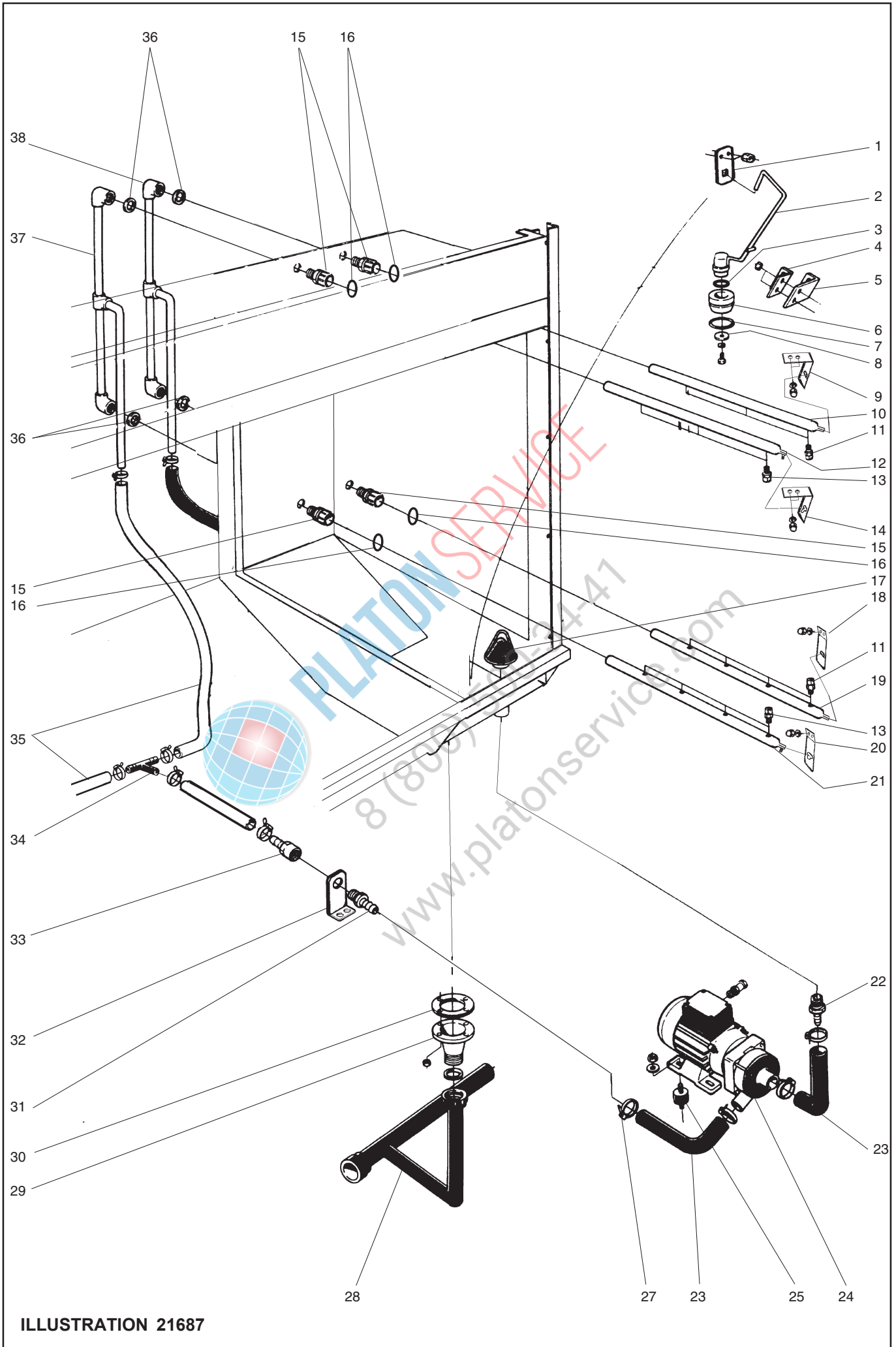

ILLUSTRATION 21687

Slutspolningstank, spolsystem
Final rinse tank, wash system
Nachspültank, Spülsystem

Illustration 21687

Utgåva
Edition
Ausgabe
6

Månad
Month
Monat
08

År
Year
Jahr
2007

Pos.	Antal Quantity Anzahl	Art.nr Art. no Art. Nr	Benämning	Description	Bezeichnung	Anm. Notes Anm.
37	1	482 71 58-00	Rör	Pipe	Röhr	1).
	1	482 71 57-00	Rör	Pipe	Röhr	
38	1	482 71 57-00	Rör	Pipe	Röhr	1).
	1	482 71 58-00	Rör	Pipe	Röhr	



PLATON SERVICE

8 (800) 500-34-41

www.platonservice.com

Fet stil = Ändring

Bold print = Change

Fettdruck = Änderung

1). Vänstermatad , Left feeded, Links richtung

2). Högermatad , Right feeded, Rechts richtung

Vänstermatad maskin med ESD - enligt bild
 Left hand feeded including ESD - acc. to picture
 Korbförderung mit ESD von links - gemäss Bild

Högermatad maskin - spegelvänd bild
 Right hand feeded - reversed picture
 Korbförderung von rechts - Spiegelbild

- A** Kallvattenanslutning
 Cold water connections
 Kaltwasseranschluss
- B** Varmvattenanslutning
 Warm water connection
 Warmwasseranschluss
- C** Till fördisktank - kallvatten
(J1) To prewash tank - cold water
 Zum Vorwaschtank - kaltwasser
- D** Till kondensbatteri - kallvatten
(J5) To condensing unit - cold water
 Zur Kondensbatterie - kaltwasser
- E** Till disktank 1 - varmvattenH
(J2) To washtank 1 - warm water
 Zum Waschtank 1 - warmwasser
- F** Till disktank 2 - varmvatten
(J3) To washtank 2 - warm water
 Zum Waschtank 2 - warmwasser
- G** Till Slutspliningstanken - varmvatten
(J4) To Final rinse tank - warm water
 Zum Nachspültank - warmwasser

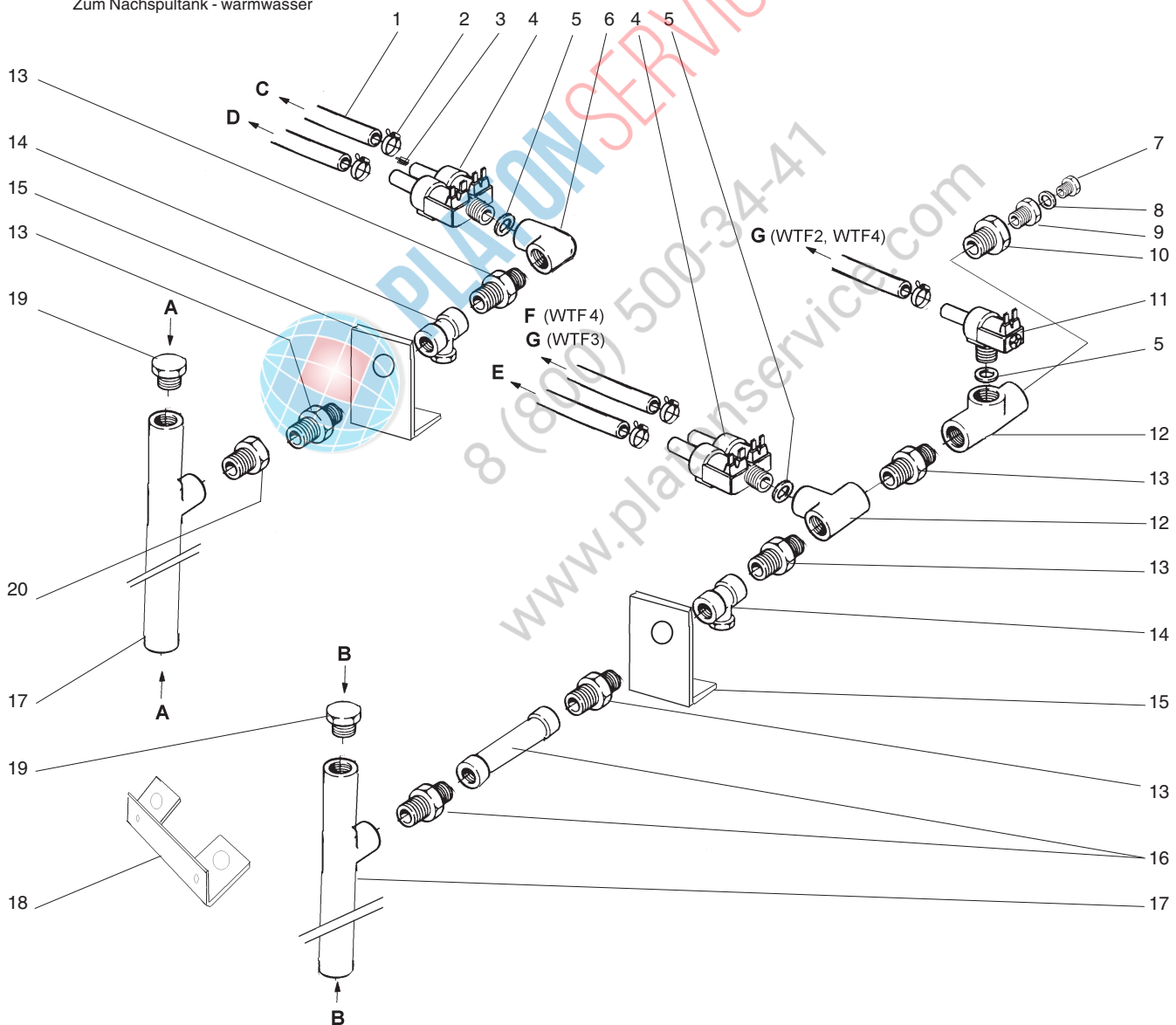

Vattenanslutningar
Water connection
Wasseransschluß

Illustration 21696

Utgåva
Edition
Ausgabe
3

Månad
Month
Monat
08

År
Year
Jahr
2007

Pos.	Antal Quantity Anzahl	Art.nr Art. no Art. Nr	Benämning	Description	Bezeichnung	Anm. Notes Anm.
	[WTF2			
	[WTF3			
	[WTF4			
1	x x x	552 00 11-00	Slang	Hose	Schlauch	1/2"
2	4 4 6	736 28 19-51	Slangklämma	Hose clamp	Schlauchklemme	D=34
3	1 1 1	482 41 22-50	Strypning, svart	Reducer, black	Drosselung, schwarz	5 l/min
4	1 2 2	ST0 28 77-00	Magnetventil 2-väg	Solenoid valve 2-way	Magnetventil 2-weg	24V 50/60Hz
5	2 2 3	482 41 21-20	Strypning, grå	Reducer, grey	Drosselung, grau	20 l/min
6	1 1 1	742 11 15-20	Rörvinkel	Angular tube	Rohrwinkelstück	3/4"
7	1 1 1	741 52 09-24	Propp	Plug	Pfropfen	1/8"
8	1 1 1	552 21 10-00	Packning	Gasket	Dichtung	16/10 T=1,5
9	1 1 1	741 41 07-20	Bussning	Bushing	Buchse	1/8"-1/2"
10	1 1 1	741 41 14-20	Bussning	Bushing	Buchse	1/2"-3/4"
11	1 - 1	482 37 36-00	Magnetventil	Solenoid valve	Magnetventil	1). 24V 50/60Hz
	1 - 1	482 41 20-00	Magnetventil	Solenoid valve	Magnetventil	2). 24V 50/60Hz
12	1 1 2	742 51 15-20	T-rör	T-tube	T-rohr	3/4"
13	6 6 7	741 31 15-22	Nippel	Nipple	Nippel	3/4"
14	2 2 2	428 16 20-00	Filter	Strainer	Sieb	3/4"
15	2 2 2	ST0 28 69-00	Fästvinkel	Attachment	Befestigung	
16	1 1 1	ST0 28 67-00	Rör kpl.	Pipe cpl.	Rohr kpl.	
17	2 2 2	ST0 28 66-00	Rör kpl.	Pipe cpl.	Rohr kpl.	
18	1 1 1	ST0 28 70-00	Fästvinkel	Attachment	Befestigung	
19	2 2 2	741 52 15-24	Propp	Plug	Pfropfen	1/8"
20	1 1 1	63 59 70-03	Koppling	Joint	Kupplung	3/4"-3/4"

Fet stil = Ändring
Bold print = Change
Fettdruck = Änderung

1). T.o.m. 2005, Vecka 09
2). Fr.o.m. 2005, Vecka 10

To 2005, week 09
From 2005, week 10

Zu 2005, wochen 09
Ab. 2005, wochen 10

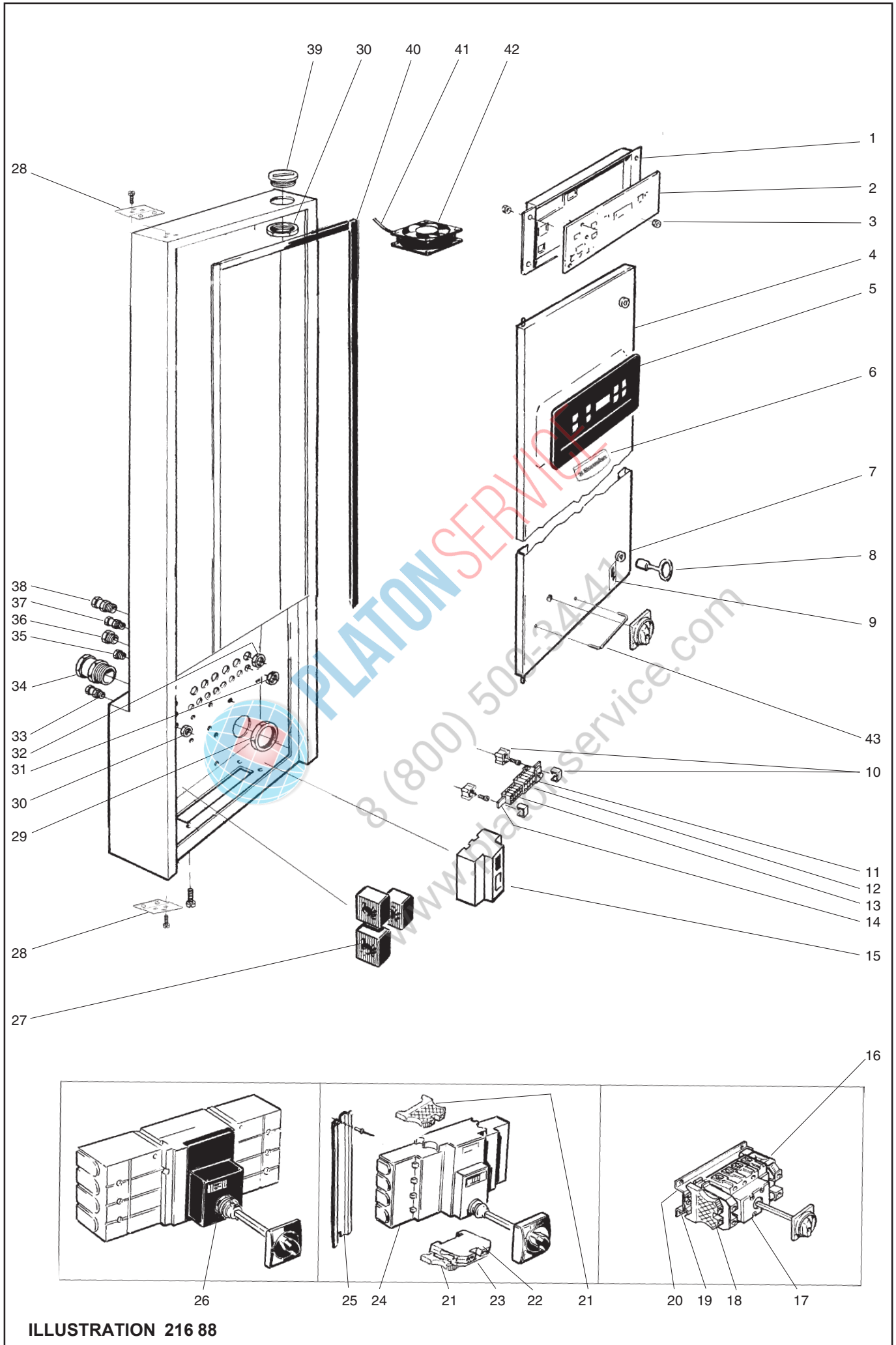

ILLUSTRATION 216 88

Kopplingskåp, plåtar + eldetaljer Switch cabinet, plates + electrical parts Schaltschrank, Bleche + elekt. Teile			Illustration 21688			Utgåva Edition Ausgabe 5	Månad Month Monat 08	År Year Jahr 2007
Pos.	Antal Quantity Anzahl	Art.nr Art. no Art. Nr	Benämning	Description	Bezeichnung	Anm. Notes Anm.		
	[WTF2					
	[WTF3					
	[WTF4					
1	1	1	1	STO 26 63-00	Kretskort täckplåt	Cover plate PCB	Deckplatte, Schaltkarte	
2	1	1	1	STO 34 89-00	Kretskort	PCB	Schaltkarte	A1
3	10	10	10	491 45 03-02	Distans	Spacer	Distanz	
4	1	1	1	STO 26 60-00	Dörr	Door	Tür	
5	1	1	1	548 63 42-01	Manöverpanel	Control panel	Schalttafel	
6	1	1	1	511 61 88-00	Skylt	Sign	Schild	
7	2	2	2	428 15 25-00	Snabblås	Quick lock	Schloss	
8	2	2	2	428 15 25-01	Nyckel	Key	Schlüssel	
9	1	1	1	552 21 61-00	Blixt	Sign	Schild	
10	2	2	2	762 71 70-90	Skenhållare	Holder	Halter	
11	2	2	2	762 71 85-90	Klämbygel, gul/grön	Clamping piece, yellow/green	Klemmbügel, gelb/grün	
12	5	4	3	762 71 83-90	Klämbygel, gul/grön	Clamping piece, yellow/green	Klemmbügel, gelb/grün	
13	12	12	10	762 71 80-90	Klämbygel, gul/grön	Clamping piece, yellow/green	Klemmbügel, gelb/grün	
14	1	1	1	477 76 81-05	Jordskena	Earth-connection bar	Erdverbindungsschiene	
15	1	1	1	STO 27 93-00	Effektmätare	Power meter	Leistungsmesser	1).
	1	1	1	STO 27 94-00	Effektmätare	Power meter	Leistungsmesser	2).
16	1	1	1	552 22 52-06	Jordplint	Earth connection	Erder	2).
	-	-	1	552 22 52-06	Jordplint	Earth connection	Erder	1).
17	1	1	1	STO 28 60-00	Brytare 80A	Switch 80A	Shalter 80A	2).
	1	-	-	STO 28 61-00	Brytare 125A	Switch 125A	Shalter 125A	1).
18	1	1	1	552 22 55-00	Ändstöd	End support	Stütze	
19	-	-	1	475 93 46-03	Monter.skena L=110	Mounting slide	Montagescheine	1).
	1	1	1	475 93 46-03	Monter.skena	Mounting slide	Montagescheine	2).
20	-	-	1	482 68 58-01	Distansplåt	Spacer plate	Distanzblech	1).
	1	1	1	482 68 58-01	Distansplåt	Spacer plate	Distanzblech	2).
21	-	2	-	552 22 55-00	Ändstöd	End support	Stütze	1).
22	-	1	-	552 22 52-07	Jordplint	Earth connection	Erder	1).
23	-	1	-	552 22 54-03	Ändplatta	End plate	Endplatte	1).
24	-	1	-	428 06 98-00	Brytare 125A	Switch 125A	Shalter 125A	1).
25	-	1	-	475 93 46-07	Monter.skena L=180	Mounting slide	Montagescheine	1).
26	-	-	1	428 06 99-00	Brytare 160A	Switch 160A	Shalter 160A	1).
27	3	3	3	STO 27 95-00	Strömtrafo	Current Transformer	Transformator	1).
28	2	2	2	STO 26 62-00	Dörrled	Door hinge	Scharnier	200/5A
29	2	2	2	STO 28 64-08	Mutter	Nut	Mutter	M63x1,5
30	X	X	X	STO 28 64-02	Mutter	Nut	Mutter	M16x1,5
31	X	X	X	STO 28 64-03	Mutter	Nut	Mutter	M20x1,5
32	X	X	X	STO 28 64-04	Mutter	Nut	Mutter	M25x1,5
33	X	X	X	STO 31 45-09	Hylsa	Sleeve	Hülse	M16x1,5
34	1	1	1	STO 31 45-15	Hylsa	Sleeve	Hülse	M63x1,5
35	X	X	X	STO 32 90-02	Avsl. propp	End plug	Schlussstück	M16x1,5
	X	X	X	STO 32 90-03	Avsl. propp	End plug	Schlussstück	M20x1,5
	X	X	X	STO 32 90-04	Avsl. propp	End plug	Schlussstück	M25x1,5

Fet stil = Ändring

Bold print = Change

Fettdruck = Änderung

1). Eluppvärmd, Electrical heated, Elekt. Erwärmung

2). Ånguppvärmd, Steam heated, Dampferwärmung

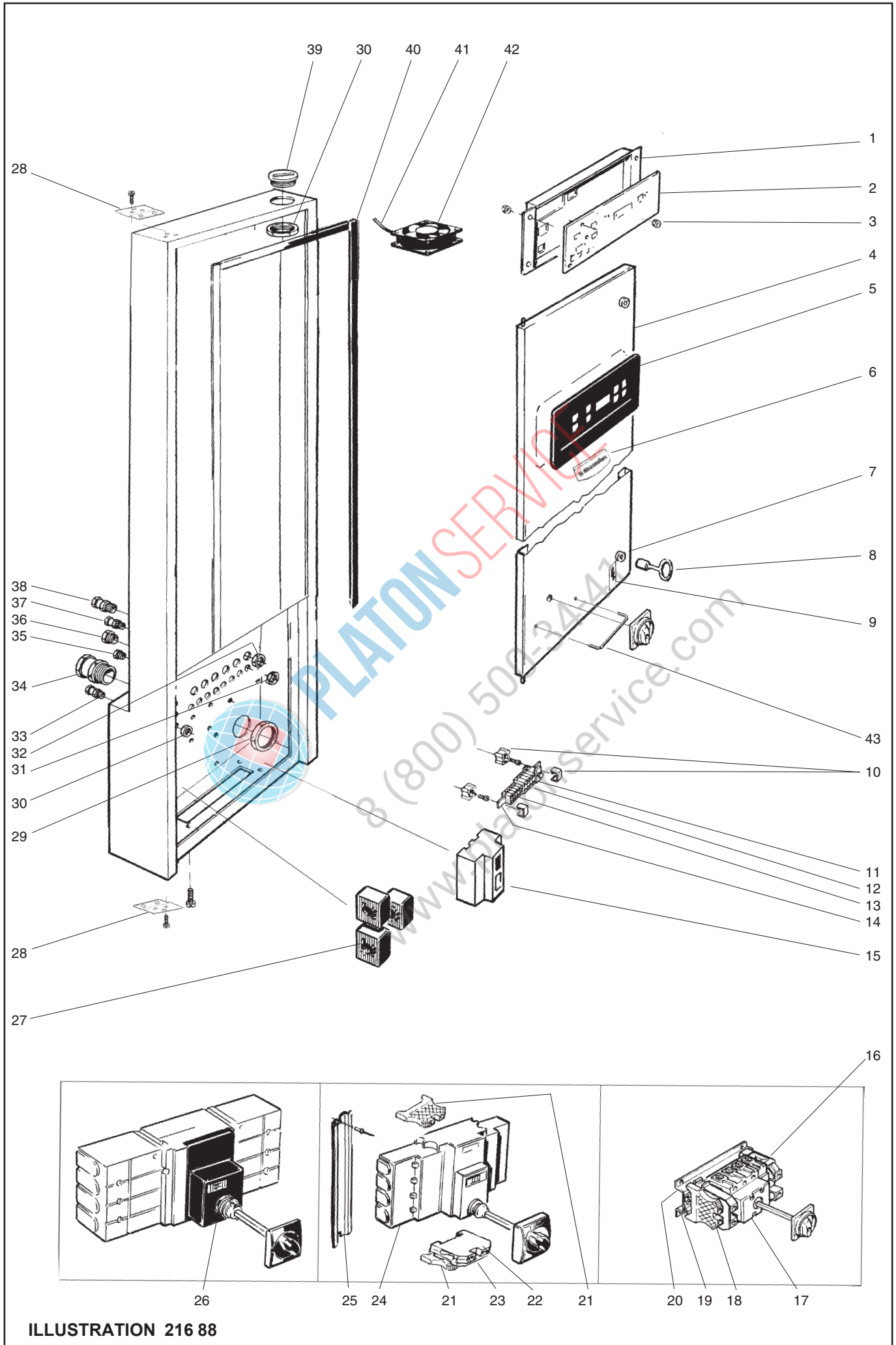

ILLUSTRATION 216 88

Kopplingskåp, plåtar + eldetaljer
Switch cabinet, plates + electrical parts
Schaltschrank, Bleche + elekt. Teile

Illustration 21688

Utgåva
Edition
Ausgabe
5

Månad
Month
Monat
08

År
Year
Jahr
2007

Pos.	Antal Quantity Anzahl	Art.nr Art. no Art. Nr	Benämning	Description	Bezeichnung	Anm. Notes Anm.
	[[[WTF2 WTF3 WTF4			
36	X X X	ST0 32 90-03	Avsl. propp	End plug	Schlussstück	M20x1,5
37	X X X	ST0 31 45-10	Hylsa	Sleeve	Hülse	M20x1,5
38	X X X	ST0 31 45-11	Hylsa	Sleeve	Hülse	M25x1,5
39	1 1 1	ST0 32 90-08	Avsl. propp	End plug	Schlussstück	M63x1,5
40	1 1 1	552 00 05-00	Tätninglist	Sealing strip	Dichtungseiste	
41	1 1 1	482 22 36-00	Anslutnings kabel	Connection cable	Anschluss kabel	
42	1 1 1	477 97 11-00	Kylfläkt	Fan	Gebälse	
43	1 1 -	499 65 90-01	Skyddsbygel	Protective support	Schutzbügel	1).
	- - 1	499 65 90-00	Skyddsbygel	Protective support	Schutzbügel	1).
	1 1 1	499 65 90-01	Skyddsbygel	Protective support	Schutzbügel	2).



PLATON SERVICE
8 (800) 500-34-41
www.platonservice.com

Fet stil = Ändring
Bold print = Change
Fettdruck = Änderung

1). Eluppvärmd, Electrical heated, Elekt. Erwärmung
2). Ånguppvärmd, Steam heated, Dampferwärmung

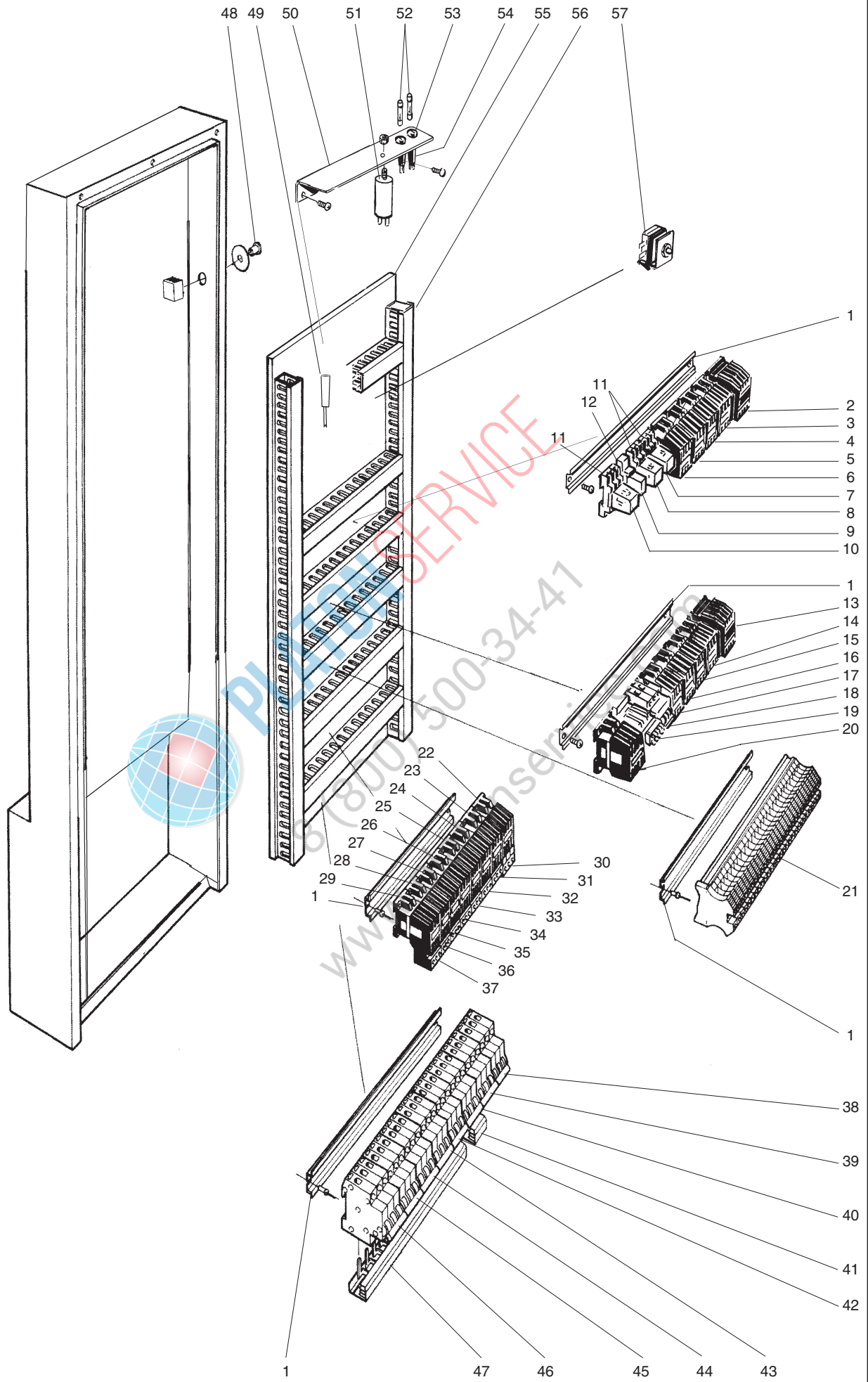

ILLUSTRATION 216 90

Kopplingskåp, Eluppvärmd maskin
Switch cabinet, Electrical heated machine
Schaltschrank, El. beheizt Maschine

Illustration 21690

Utgåva
Edition
Ausgabe
4

Månad
Month
Monat
08

År
Year
Jahr
2011

Pos.	Antal Quantity Anzahl	Art.nr Art. no Art. Nr	Benämning	Description	Bezeichnung	Anm. Notes Anm.
1	4	475 93 46-15	Monteringskena	Mounting slide	Montagescheine	
2	1	ST0 27 90-02	Kontaktor K15	Contacto K15	Kontaktor K15	
3	1	ST0 27 90-03	Kontaktor K14	Contacto K14	Kontaktor K14	4).
4	1	ST0 27 90-03	Kontaktor K13	Contacto K13	Kontaktor K13	1). 2). 3).
5	1	ST0 27 90-03	Kontaktor K12	Contacto K12	Kontaktor K12	3).
6	1	ST0 27 90-03	Kontaktor K11	Contacto K11	Kontaktor K11	2). 3).
7	1	552 21 22-01	Relä K23	Relay K23	Relais K23	3-pol
8	1	552 21 22-01	Relä K22	Relay K22	Relais K22	3-pol
9	1	552 21 23-01	Relä K21	Relay K21	Relais K21	1-pol
10	1	552 21 22-01	Relä K20	Relay K20	Relais K20	3-pol
11	3	552 21 22-00	Socket	Mounting slide	Montagescheine	3-pol.
12	1	552 21 23-00	Socket	Mounting slide	Montagescheine	1-pol.
13	1	ST0 27 90-02	Kontaktor K151	Contacto K151	Kontaktor K151	
14	1	ST0 27 90-03	Kontaktor K141	Contacto K141	Kontaktor K141	
15	1	ST0 27 90-03	Kontaktor K131	Contacto K131	Kontaktor K131	1). 2). 3).
16	1	ST0 27 90-03	Kontaktor K121	Contacto K121	Kontaktor K121	3).
17	1	ST0 27 90-03	Kontaktor K111	Contacto K111	Kontaktor K111	2). 3).
18	1	552 22 23-10	Automatsäkring F13	Automatic fuse F13	Automatsicherung F13	3). 10A
19	1	428 06 86-01	Transformator T3	Transformer T3	Transformator T3	
20	1	767 51 14-09	Kontaktor K5	Contacto K5	Kontaktor K5	
21	1	ST0 28 83-00	Koppl. plint kpl. X2	Terminal block cpl. X2	Klemmeleiste kpl. X2	
22	1	ST0 27 90-03	Kontaktor K18	Contacto K18	Kontaktor K18	
23	1	ST0 27 90-03	Kontaktor K8	Contacto K8	Kontaktor K8	
24	1	ST0 27 90-03	Kontaktor K7	Contacto K7	Kontaktor K7	
25	1	ST0 27 90-03	Kontaktor K6	Contacto K6	Kontaktor K6	
26	1	ST0 27 90-03	Kontaktor K3	Contacto K3	Kontaktor K3	3).
27	1	ST0 27 90-03	Kontaktor K2	Contacto K2	Kontaktor K2	2). 3).
28	1	ST0 27 90-03	Kontaktor K4	Contacto K4	Kontaktor K4	1). 2). 3).
29	1	ST0 27 90-03	Kontaktor K1	Contacto K1	Kontaktor K1	1). 2). 3).
30	1	ST0 28 54-05	Överströmsrelä N18	Overload protection N18	Überlastungsschutz N18	0,6- 0,9A
31	1	ST0 28 54-07	Överströmsrelä N8	Overload protection N8	Überlastungsschutz N8	1,2- 1,8A
32	1	ST0 28 54-05	Överströmsrelä N7	Overload protection N7	Überlastungsschutz N7	0,6- 0,9A
33	1	ST0 28 54-05	Överströmsrelä N6	Overload protection N6	Überlastungsschutz N6	0,6- 0,9A
34	1	ST0 28 54-10	Överströmsrelä N3	Overload protection N3	Überlastungsschutz N3	3). 4-6A
35	1	ST0 28 54-10	Överströmsrelä N2	Overload protection N2	Überlastungsschutz N2	2). 3). 4-6A
36	1	ST0 28 54-10	Överströmsrelä N4	Overload protection N4	Überlastungsschutz N4	1). 2). 3). 4-6A
37	1	ST0 28 54-10	Överströmsrelä N1	Overload protection N1	Überlastungsschutz N1	1). 2). 3). 4-6A
	1	ST0 28 54-11	Överströmsrelä N1	Overload protection N1	Überlastungsschutz N1	1). 2). 3). 7). 6-9A
	1	ST0 28 54-07	Överströmsrelä N1	Overload protection N1	Überlastungsschutz N1	1). 2). 5). 1,2- 1,8A
	1	ST0 28 54-08	Överströmsrelä N1	Overload protection N1	Überlastungsschutz N1	1). 2). 5). 6). 1,8-2,7A
38	1	552 22 23-32	Automatsäkring F12	Automatic fuse F12	Automatsicherung F12	3). 32A
	1	552 22 23-10	Automatsäkring F13	Automatic fuse F13	Automatsicherung F13	1). 2). 10A

1). WTF2

2). WTF3

3). WTF4

4). Torkzon

5). Fördisktank L=600,
Basic(C), Medium(B)

6). Fördisktank L=600, TOP(A)

7). **Med rostfri pump(A)**

Drying zone

Prewash tank L=600,

Basic(C), Medium(B)

Prewash tank L=600, TOP(A)

With stainless steel pump (A)

Torkenzone

Vorwaschzone L=600,

Basic(C), Medium(B)

Vorwaschzone L=600, TOP(A)

Mit Edelstahl-Pumpe (A)

Fet stil = Ändring

Bold print = Change

Fettdruck = Änderung

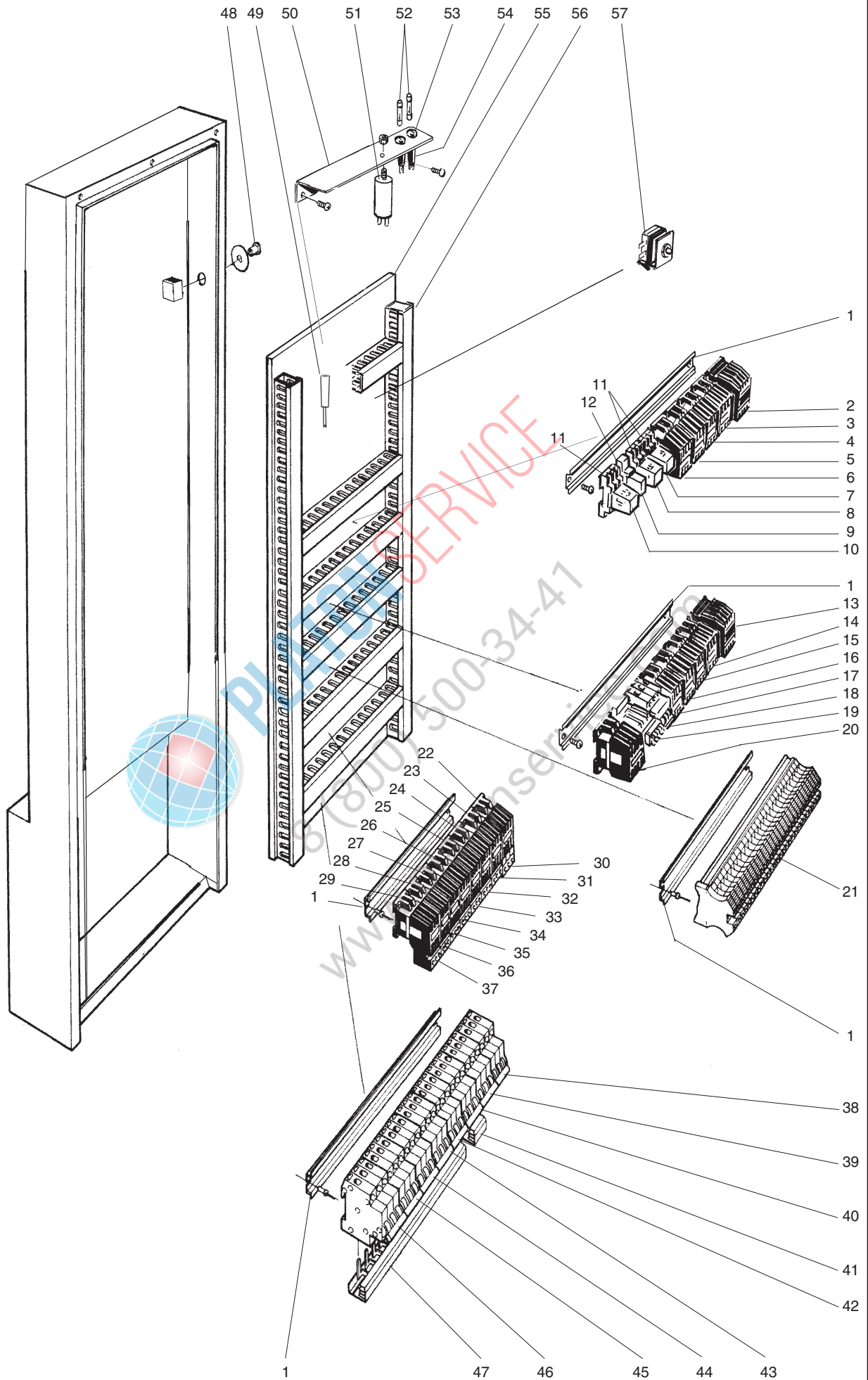

ILLUSTRATION 216 90

Kopplingskåp, Eluppvärmd maskin
Switch cabinet, Electrical heated machine
Schaltschrank, El. beheizt Maschine

Illustration 21690

Utgåva
Edition
Ausgabe
4

Månad
Month
Monat
08

År
Year
Jahr
2011

Pos.	Antal Quantity Anzahl	Art.nr Art. no Art. Nr	Benämning	Description	Bezeichnung	Anm. Notes Anm.
39	1	552 22 23-32	Automatsäkring F12	Automatic fuse F12	Automatsicherung F12	1). 2).
	1	552 22 23-32	Automatsäkring F11	Automatic fuse F11	Automatsicherung F11	3).
40	1	552 22 23-32	Automatsäkring F10	Automatic fuse F10	Automatsicherung F10	2). 3).
41	1	552 55 08-03	Fasskena	Phase bar	Phasenschiene	2). 3).
42	1	552 22 23-16	Automatsäkring F5	Automatic fuse F5	Automatsicherung F5	1). 2). 3).
43	1	552 22 23-40	Automatsäkring F9	Automatic fuse F9	Automatsicherung F9	1). 2). 3).
44	1	552 22 23-20	Automatsäkring F8	Automatic fuse F8	Automatsicherung F8	1). 2). 3).
45	1	552 22 23-20	Automatsäkring F7	Automatic fuse F7	Automatsicherung F7	2). 3).
46	1	552 22 23-20	Automatsäkring F6	Automatic fuse F6	Automatsicherung F6	1). 2). 3).
47	1	552 55 08-05	Fasskena	Phase bar	Phasenschiene	2). 3).
	1	552 55 08-06	Fasskena	Phase bar	Phasenschiene	1).
48	1	428 07 60-00	Nödstoppsbrytare	Emergency switch	Notschalter	
49	1	ST0 28 82-00	Verktyg ADO	Tool ADO	Werkzeug ADO	
50	1	428 07 69-00	L-profil	L-profile	L-profil	
51	1	763 76 68-45	Kondensator 5MF, C3	Condenser 5MF, C3	Kondensator 5MF, C3	
52	2	428 02 86-01	Glassäkring	Glass-tube fuse	Glasrohr sicherung	1,6A
53	2	552 20 37-00	Säkringsinsats	Fuse Socket	Sicherungsfassung	
54	2	552 20 37-00	Säkringshållare	Fuse holder	Sicherungshalterung	
55	1	ST0 26 61-00	Kopplingsplåt	Connection plate	Anschlussblech	
56	4m	87 79 50-205	Kabelkanal	Canal Passage	Kablekanal	
57	1	481 95 01-05	Överhettningsskydd F2	Overheaten protection F2	Überhitzungsschutz F2	4).



- 1). WTF2
- 2). WTF3
- 3). WTF4
- 4). Torkzon
- 5). Fördisktank L=600, Basic(C), Medium(B)
- 6). Fördisktank L=600, TOP(A)
- 7). **Med rostfri pump(A)**

Drying zone
Prewash tank L=600, Basic(C), Medium(B)
Prewash tank L=600, TOP(A)
With stainless steel pump (A)

Torkenzone
Vorwaschzone L=600, Basic(C), Medium(B)
Vorwaschzone L=600, TOP(A)
Mit Edelstahl-Pumpe (A)

Fet stil = Ändring
Bold print = Change
Fettdruck = Änderung

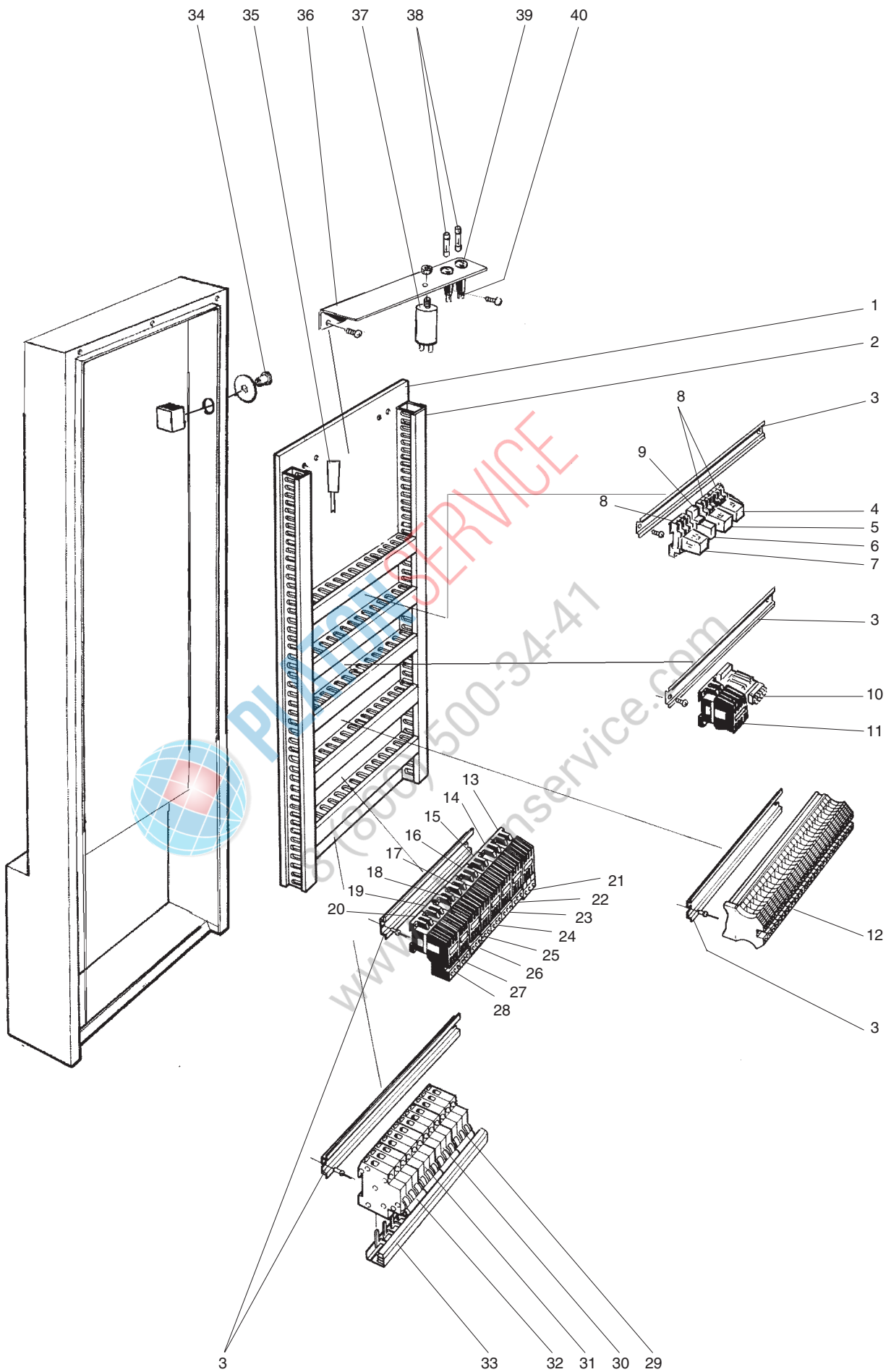

ILLUSTRATION 216 89

Kopplingskåp, Ånguppvärmd maskin Switch cabinet, Steam heated machine Schaltschrank, Dampfbeheizt Maschine			Illustration 21689			Utgåva Edition Ausgabe 4	Månad Month Monat 08	År Year Jahr 2011
Pos.	Antal Quantity Anzahl	Art.nr Art. no Art. Nr	Benämning	Description	Bezeichnung	Anm. Notes Anm.		
1	1	ST0 26 61-00	Kopplingsplåt	Connection plate	Anschlussblech			
2	4m	87 79 50-205	Kabelkanal	Canal Passage	Kablekanal			
3	1	475 93 46-03	Monter. skena	Mounting slide	Montagescheine	1).		
	1	475 93 46-06	Monter. skena	Mounting slide	Montagescheine	3).		
	1	475 93 46-07	Monter. skena	Mounting slide	Montagescheine	2). 3).		
	1	475 93 46-08	Monter. skena	Mounting slide	Montagescheine			
4	1	552 21 22-01	Relä K23	Relay K23	Relais K23	3-pol		
5	1	552 21 22-01	Relä K22	Relay K22	Relais K22	3-pol		
6	1	552 21 23-01	Relä K21	Relay K21	Relais K21	1-pol		
7	1	552 21 22-01	Relä K20	Relay K20	Relais K20	3-pol		
8	3	552 21 22-00	Sockel	Mounting slide	Montagescheine	3-pol.		
9	1	552 21 23-00	Sockel	Mounting slide	Montagescheine	1-pol.		
10	1	428 06 86-01	Transformator T3	Transformer T3	Transformator T3			
11	1	ST0 27 90-03	Kontaktor K5	Contactactor K5	Kontaktor K5			
12	1	ST0 28 83-00	Koppl. plint kopl. X2	Terminal block cpl. X2	Klemmeleiste kpl. X2			
13	1	ST0 27 90-03	Kontaktor K18	Contactactor K18	Kontaktor K18			
14	1	ST0 27 90-03	Kontaktor K8	Contactactor K8	Kontaktor K8			
15	1	ST0 27 90-03	Kontaktor K7	Contactactor K7	Kontaktor K7			
16	1	ST0 27 90-03	Kontaktor K6	Contactactor K6	Kontaktor K6			
17	1	ST0 27 90-03	Kontaktor K3	Contactactor K3	Kontaktor K3	3).		
18	1	ST0 27 90-03	Kontaktor K2	Contactactor K2	Kontaktor K2	2). 3).		
19	1	ST0 27 90-03	Kontaktor K4	Contactactor K4	Kontaktor K4	1). 2). 3).		
20	1	ST0 27 90-03	Kontaktor K1	Contactactor K1	Kontaktor K1	1). 2). 3).		
21	1	ST0 28 54-05	Överströmsrelä N18	Overload protection N18	Überlastungsschutz N18			0,6- 0,9A
22	1	ST0 28 54-07	Överströmsrelä N8	Overload protection N8	Überlastungsschutz N8			1,2- 1,8A
23	1	ST0 28 54-05	Överströmsrelä N7	Overload protection N7	Überlastungsschutz N7			0,6- 0,9A
24	1	ST0 28 54-05	Överströmsrelä N6	Overload protection N6	Überlastungsschutz N6			0,6- 0,9A
25	1	ST0 28 54-10	Överströmsrelä N3	Overload protection N3	Überlastungsschutz N3	3).		4-6A
26	1	ST0 28 54-10	Överströmsrelä N2	Overload protection N2	Überlastungsschutz N2	2). 3).		4-6A
27	1	ST0 28 54-10	Överströmsrelä N4	Overload protection N4	Überlastungsschutz N4	1). 2). 3).		4-6A
28	1	ST0 28 54-10	Överströmsrelä N1	Overload protection N1	Überlastungsschutz N1	1). 2). 3).		4-6A
	1	ST0 28 54-11	Överströmsrelä N1	Overload protection N1	Überlastungsschutz N1	1). 2). 3). 6).		4-6A
	1	ST0 28 54-07	Överströmsrelä N1	Overload protection N1	Überlastungsschutz N1	1). 2). 4).		1,2- 1,8A
	1	ST0 28 54-08	Överströmsrelä N1	Overload protection N1	Überlastungsschutz N1	1). 2). 4). 5).		1,8-2,7A
29	1	552 22 23-16	Automatsäkring F5	Automatic fuse F5	Automatsicherung F5	1). 2). 3).		16A
30	1	552 22 23-10	Automatsäkring F13	Automatic fuse F13	Automatsicherung F13	1).2).		10A
31	1	552 22 23-20	Automatsäkring F7	Automatic fuse F7	Automatsicherung F7	2). 3).		20A
32	1	552 22 23-20	Automatsäkring F6	Automatic fuse F6	Automatsicherung F6	1). 2). 3).		20A
33	1	552 55 08-04	Fasskena	Phase bar	Phasenschiene	2). 3).		
	1	552 55 08-03	Fasskena	Phase bar	Phasenschiene	1).		
34	1	428 07 60-00	Nödstoppsbrytare	Emergency switch	Notschalter			
35	1	ST0 28 82-00	Verktyg ADO	Tool ADO	Werkzeug ADO			
36	1	428 07 69-00	L-profil	L-profile	L-profil			
37	1	763 76 68-45	Kondensator 5MF, C3	Condenser 5MF, C3	Kondensator 5MF, C3			
38	2	428 02 86-01	Glassäkring	Glass-tube fuse	Glasrohr sicherung			1,6A
39	2	552 20 37-00	Säkringsinsats	Fuse Socket	Sicherungsfassung			
40	2	552 20 37-00	Säkringshållare	Fuse holder	Sicherungshalterung			

- 1). WTF2
- 2). WTF3
- 3). WTF4

Fet stil = Ändring
Bold print = Change
Fettdruck = Änderung

- 4). Fördisktank L=600, Basic(C), Medium(B)
- 5). Fördisktank L=600, TOP(A)
- 6). **Med rostfri pump(A)**

Prewash tank L=600, Basic(C), Medium(B)
Prewash tank L=600, TOP(A)
With stainless steel pump (A)

Vorwaschzone L=600, Basic(C), Medium(B)
Vorwaschzone L=600, TOP(A)
Mit Edelstahl-Pumpe (A)

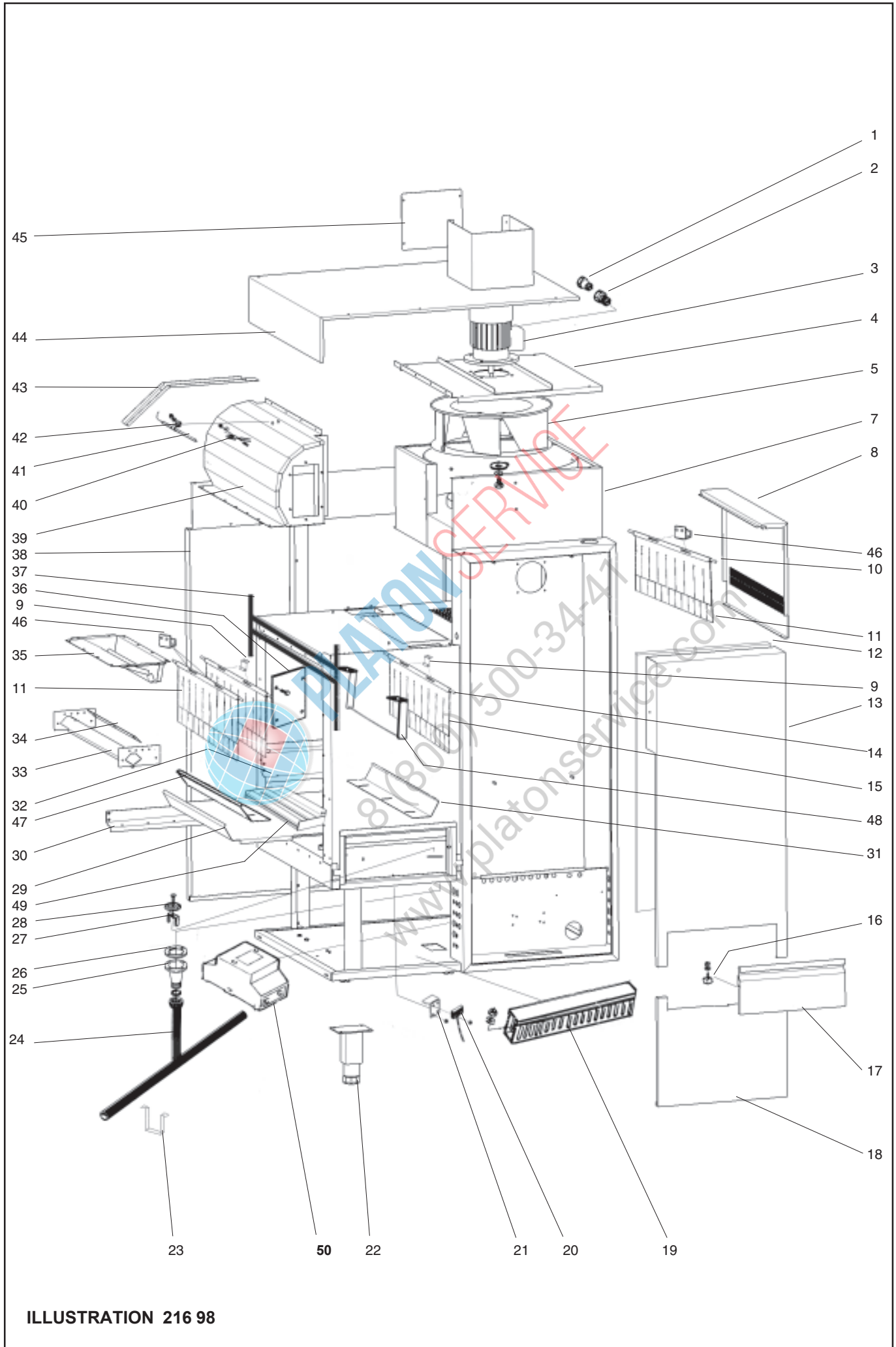

ILLUSTRATION 216 98

Torktunnel L=1100, fläkt + avlopp, plåtar
Drying tunnel L=1100, fan + drain, plates
Trockenzone L=1100, Gebläse + Ablauf, Bleche

Illustration 21698

Utgåva
Edition
Ausgabe
6

Månad
Month
Monat
02

År
Year
Jahr
2008

Pos.	Antal Quantity Anzahl	Art.nr Art. no Art. Nr	Benämning	Description	Bezeichnung	Anm. Notes Anm.
1	1	762 18 03-20	Muff	Sleeve	Stutze	Pr 18.6-15.2
2	1	762 18 06-20	Muff	Sleeve	Stutze	Pr 20.4-18.6
3	1	ST0 27 68-00	Motor	Motor	Motor	230 / 400V
4	1	ST0 27 52-00	Torkfläktstak	Top drying fan	Dach Gebläse	
5	1	830 80 78-02	Fläkthjul	Fan wheel	Gebläserad	
7	1	ST0 27 51-00	Tryckkammare	Pressure chamber	Druckraum	3).
	1	ST0 34 18-00	Tryckkammare	Pressure chamber	Druckraum	
8	1	ST0 27 65-00	Sidplåt	Side plate	Seitenplatte	3).
	1	ST0 34 22-00	Sidplåt	Side plate	Seitenplatte	
9	4	490 15 16-00	Gardinfäste	Curtain attachment	Vorhangbefestigung	
10	4	482 76 03-01	Gardinaxel	Curtain attachment	Vorhangbefestigung	
11	3	490 15 10-00	Grdin	Curtain	Vorhang	
12	x	482 15 17-00	Isolerskiva	Insulation	Isolierung	
13	1	ST0 30 33-00	Front	Front	Vorderseite	
14	1	482 76 03-02	Gardinaxel	Curtain attachment	Vorhangbefestigung	
15	1	490 15 12-00	Gardin	Curtain	Vorhang	
16	1	461 13 78-02	Magnet	Magnet	Magnet	
17	1	ST0 31 76-00	Lucka kpl	Door compl	Tür kpl	
18	1	ST0 30 32-00	Front	Front	Vorderseite	
19	1,3m 1,3m	87 79 50-205 87 79 50-206	Kabelkanal Kabelkanal	Canal passage Canal passage	Kablekanal Kablekanal	40x60 60x60
20	1	476 06 64-00	Magnetbrytare	Magn.Cont.Switch	Magnetausschate	
21	1	ST0 34 28-00	Fäste	Attachement	Befestigung	
22	4	855 64 90-00	Ben	Leg	Bein	
23	2	482 77 87-00	Avloppsbygel	Drain clamp	Ablauf Bügel	
24	1	ST0 28 74-00	Avlopp	Drain	Ablauf	
25	1	475 77 84-00	Avloppsstos	Drain pipe conn.	Ablaufstutzen	
26	1	477 73 94-00	Packning	Gasket	Dichtung	
27	1	481 71 88-00	Silstyrning	Strainer guide	Siebführung	
28	1	428 02 89-00	Sil	Strainer	Sieb	
29	1	ST0 34 13-00	Extra botten	Extra botton	Extra Boden	1).
	1	ST0 34 13-01	Extra botten	Extra botton	Extra Boden	2).
30	2	428 18 20-00	Bandgejd	Slide	Führungsleiste	
31	1	ST0 34 14-00	Ledplåt	Plate	Platte	
32	2	428 18 17-00	Bandgejd	Guiding pipe	Führungsrohr	
33	2	ST0 27 06-00	Underblås	Blow-off nozzle lower	Gebläse Düse under	3).
	2	ST0 34 03-00	Underblås	Blow-off nozzle lower	Gebläse Düse under	
34	2	ST0 27 12-00	Spjäll	Draught valve	Schieber	3).
	2	ST0 34 07-00	Spjäll	Draught valve	Schiebe	
35	1	ST0 27 13-00	Overblås	Blow-off nozzle upper	Gebläse Düse obere	3).
	1	ST0 31 96-00	Overblås	Blow-off nozzle upper	Gebläse Düse obere	
36	2	481 98 74-00	Spjäll	Draught valve	Schieber	
37	X	87 33 03-240	Packning	Gasket	Dichtung	

Fet stil = Ändring
Bold print = Change
Fettdruck = Änderung

1). Vänstermatad
2). Högermatad
3). Fr.o.m. 2004, Vecka17

Left feeded
Right feeded
From 2004, week 17

Links Richtung
Rechts Richtung
Ab. 2004, wochen17

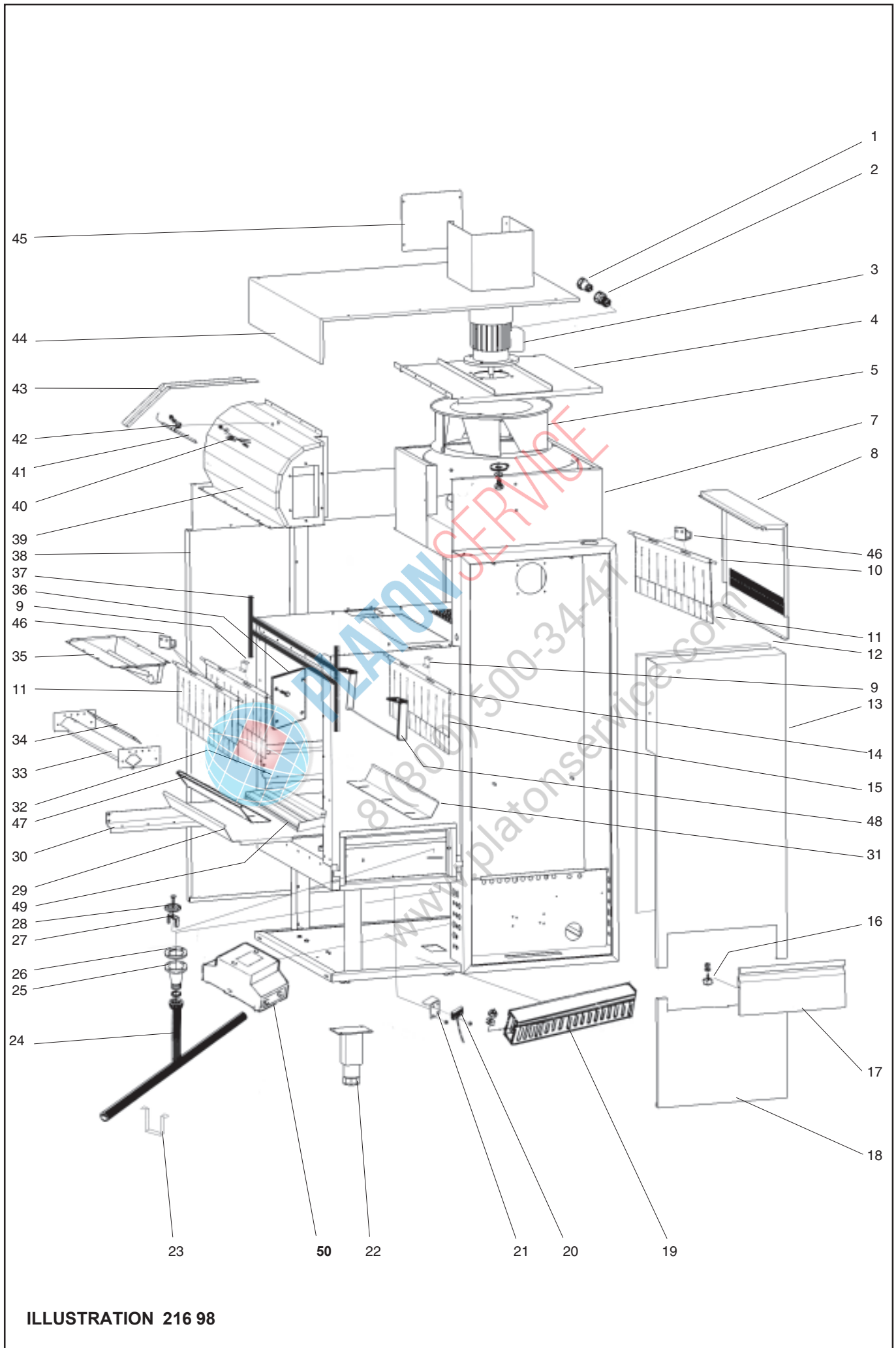

ILLUSTRATION 216 98

Torktunnel L=1100, fläkt + avlopp, plåtar
Drying tunnel L=1100, fan + drain, plates
Trockenzone L=1100, Gebläse + Ablauf, Bleche

Illustration 21698

Utgåva
Edition
Ausgabe
6

Månad
Month
Monat
02

År
Year
Jahr
2008

Pos.	Antal Quantity Anzahl	Art.nr Art. no Art. Nr	Benämning	Description	Bezeichnung	Anm. Notes Anm.
38	1	ST0 27 56-00	Baksida	Rear fase	Rückseite	
39	1	ST0 27 55-00	Kåpa	Casing	Haube	1).
	1	ST0 27 55-01	Kåpa	Casing	Haube	2).
40	1	478 08 64-01	Termistor	Thermistor	Termistor	
41	1	481 95 01-05	Öhett.skydd	Overheating prot.	Überhitz.schutz	
42	1	552 21 30-00	Hållare	Holder	Halter	
43	1	ST0 30 25-00	Kabelränna	Cable groove	kabelrinne	
44	1	ST0 27 58-00	Tak	Outer Roof	Oberseite	1).
	1	ST0 27 58-01	Tak	Outer Roof	Oberseite	2).
45	1	ST0 27 60-00	Täckplåt	Cover plate	Deckplatte	
46	4	ST0 31 72-00	Gardinfäste	Curtain attachment	Vorhangbefestigung	
47	1	ST0 34 14-01	Ledplåt	GuidePlate	Führungsblech	
48	1	ST0 31 05-00	Gardin Insugningskydd	Curtain protective grid	Vorhang Schutzgitter	
49	1	ST0 30 22-00	Ledplåt	GuidePlate	Führungsblech	
50	1	482 42 20-09	Transformator	Transformer	Transformator	480VA, 230 / 400V



PLATON SERVICE
8 (800) 500-34-47
www.platonservice.com

Fet stil = Ändring
Bold print = Change
Fettdruck = Änderung

1). Vänstermatad
2). Högermatad
3). Fr.o.m. 2004, Vecka17

Left feeded
Right feeded
From 2004, week 17

Links Richtung
Rechts Richtung
Ab. 2004, wochen17

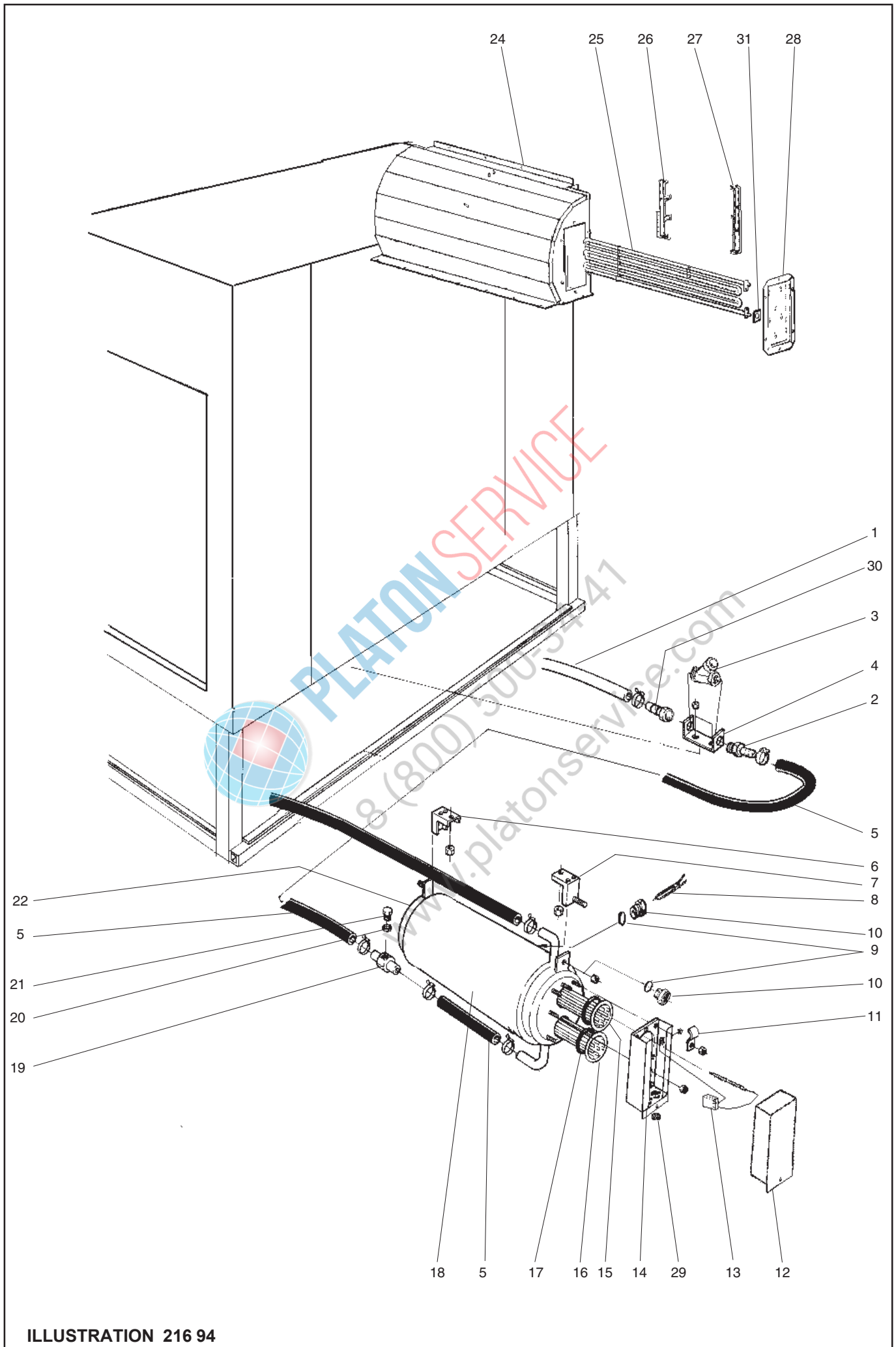

ILLUSTRATION 216 94

Torktunnel L=1100, Genomströmmare, eluppvärmd Drying tunnel L=1100, Booster, electr. heated Trockenzone L=1100, Durclauerhitzer, elektr. Beheizt				Illustration 21694		Utgåva Edition Ausgabe 5	Månad Month Monat 08	År Year Jahr 2007
Pos.	Antal Quantity Anzahl	Art.nr Art. no Art. Nr	Benämning	Description	Bezeichnung	Anm. Notes Anm.		
1	x	552 00 11-00	Slang	Hose	Schlauch			
2	1	552 21 40-21	Slangkoppling	Hose nipple	Schlauchnippel			
3	1	ST0 28 92-00	Reduceringsventil	Reducing valve	Reduktionsventil			
4	1	482 68 91-00	Fäste	Attachment	Befestigung			
5	x	552 00 13-00	Slang	Hose	Schlauch			
6	1	482 68 57-00	Fäste	Attachment	Befestigung			
7	1	482 68 56-00	Fäste	Attachment	Befestigung			
8	1	428 15 27-00	Termistor	Thermistor	Termistor			
9	2	740 43 03-14	O-ring	O-ring	O-ring			5,3-2,4
10	2	478 04 46-00	Förskruvning	Pipe nipple	Verschraubung			
11	1	552 21 30-00	Klammer	Clamp	Schelle			
12	1	499 83 78-00	Lock	Hood cover	Deckel			
13	1	481 95 01-02	Överhettningsskydd	Overheating protection	Überhitz. schutz			
14	1	ST0 37 55-00	Kåpa	Hood	Haube			
15	1	482 40 65-02	Element 6 kW	Heating element 6 kW	Heizkörper 6 kW			3).
	1	482 40 65-00	Element 10 kW	Heating element 10 kW	Heizkörper 10 kW			4).
16	1	478 04 08-00	Element 12 kW	Heating element 12 kW	Heizkörper 12 kW			230 / 400V
17	2	740 48 31-05	O-ring	O-ring	O-Ring			
18	1	428 07 56-00	Isolering	Insulation	Isolierung			
19	1	552 21 39-00	Anslutningsnippel	Connection nipple	Anlusnippel			
20	1	552 21 10-00	Packning	Gasket	Dichtung			
21	1	741 52 09-24	Plugg	Plug	Stöpsel			1/8"
22	1	ST0 34 43-00	Genomströmmare, kpl.	Booster, cpl.	Durchlauferhitzer, Kpl.			
24	1	ST0 27 55-00	Anslutningskåpa	Element cape	Elementgehäusen			1).
	1	ST0 27 55-01	Anslutningskåpa	Element cape	Elementgehäusen			2).
25	3	ST0 30 38-00	Element 3 kW	Heating element 3 kW	Heizkörper 3 kW			230 / 400V
26	6	ST0 31 71-00	Element styrning	Heating element guide	Heizkörper führung			
27	6	ST0 31 70-00	Element styrning	Heating element guide	Heizkörper führung			
28	1	ST0 28 55-00	Element fläns	Heating element flange	Heizkörper Flansch			
29	2	762 12 32-00	Genomföring	Inlet	Durchführung			D=15
30	1	ST0 28 57-00	Slangkoppling	Hose nipple	Schlauchnippel			
31	6	476 04 02-00	Packning	Gasket	Dichtung			

Fet stil = Ändring
Bold print = Change
Fettdruck = Änderung

- 1). Vänstermatad maskin / Left hand side fed machine / Maschine mit Linkszuführung
2). Högermatad maskin / Right hand side fed machine / Maschine mit Rechtszuführung
3). **WTF2, WTF3**
4). **WTF4**

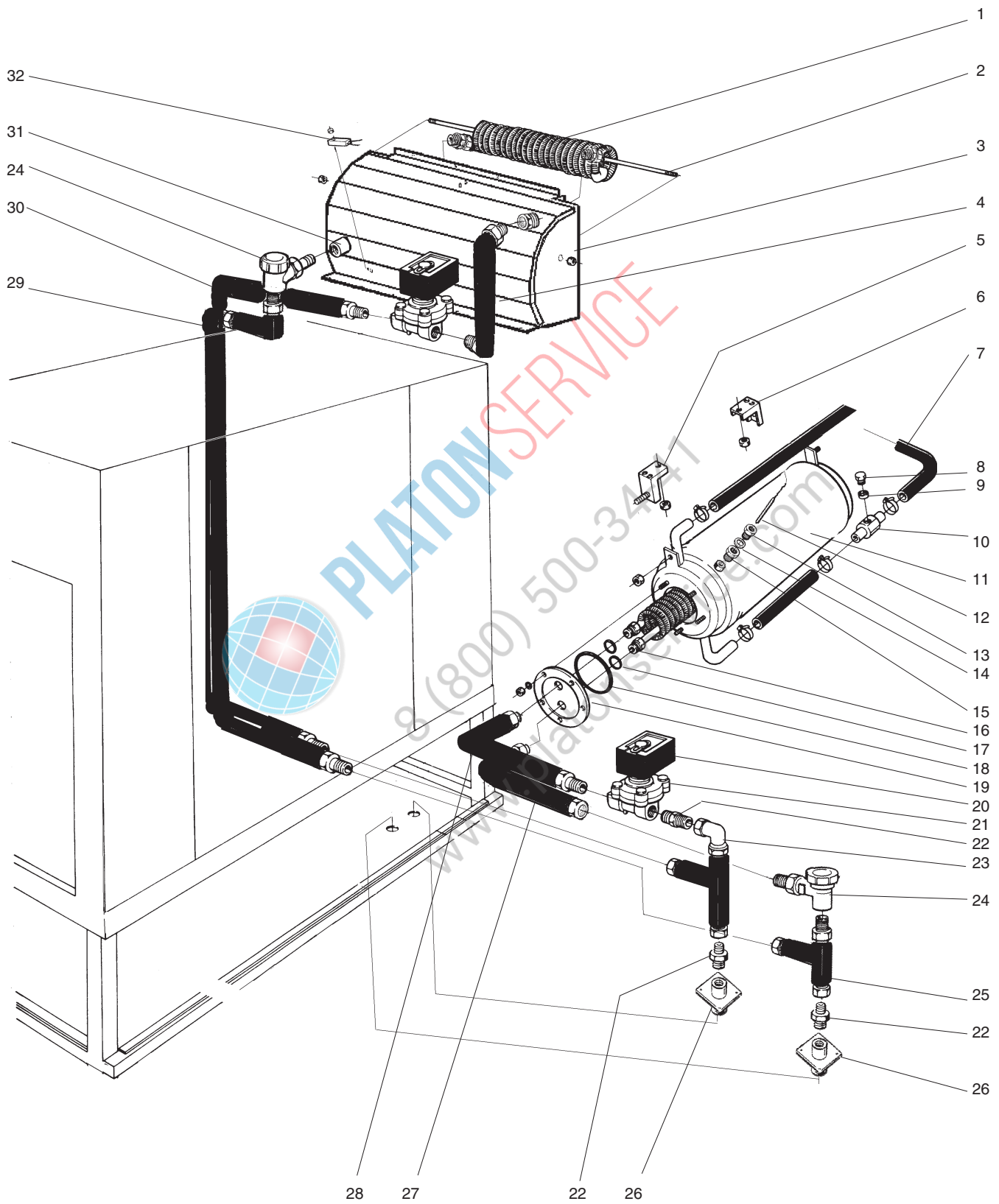

ILLUSTRATION 216 95

Torktunnel L=1100, Genomströmmare, ånguppvärmd, DUO
 Drying tunnel L=1100, Booster, steam heated, DUO
 Trockenzone L=1100, Durclauerhitzer, Dampfbeheiz, DUO

Illustration 21695

Utgåva
Edition
Ausgabe
2

Månad
Month
Monat
08

År
Year
Jahr
2007

Pos.	Antal Quantity Anzahl	Art.nr Art. no Art. Nr	Benämning	Description	Bezeichnung	Anm. Notes Anm.
1	1	ST0 31 35-00	Ångslinga	Steam coil	Dampfschleife	1).
	1	ST0 31 35-01	Ångslinga	Steam coil	Dampfschleife	2).
2	1	ST0 37 20-00	Stång	Bar	Stange	
3	1	ST0 31 37-00	Anslutningskåpa	Element cape	Elementgehäusen	1).
	1	ST0 31 37-01	Anslutningskåpa	Element cape	Elementgehäusen	2).
4	1	ST0 34 97-00	Rör, kpl.	Pipe, cpl.	Rohr, Kpl.	1).
	1	ST0 34 97-01	Rör, kpl.	Pipe, cpl.	Rohr, Kpl.	2).
5	1	482 68 56-00	Fäste	Attachment	Befestigung	
6	1	482 68 57-00	Fäste	Attachment	Befestigung	
7	x	552 00 13-00	Slang	Hose	Schlauch	
8	1	741 52 09-24	Plugg	Plug	Stöpsel	1/8"
9	1	552 21 10-00	Packning	Gasket	Dichtung	
10	1	552 21 39-00	Anslutningsnippel	Connection nipple	Anslusnippel	
11	1	ST0 34 44-00	Genomströmmare, kpl.	Booster, cpl.	Durchlauferhitzer, Kpl.	
12	1	428 15 27-00	Termistor	Thermistor	Termistor	
13	1	478 04 46-00	Förskrivning	Pipe nipple	Verschraubung	
14	1	740 43 03-14	O-ring	O-ring	O-ring	5,3-2,4
15	1	482 63 02-00	Bussning	Bush	Buchse	
16	1	491 35 44-00	Ångslinga	Steam coil	Dampfschleife	
17	2	552 21 10-03	Packning	Gasket	Dichtung	
18	1	477 74 08-00	O-ring	O-ring	O-Ring	
19	1	482 56 80-00	Fläns	Flange	Flansch	
20	2	463 97 00-00	Kabelhuvud	Cable terminal	Kabelschluß	
21	2	482 17 40-03	Magnetventil	Solenoid valve	Magnetventil	50 Hz
	2	482 17 40-06	Magnetventil	Solenoid valve	Magnetventil	60 Hz
22	3	741 31 15-22	Nippel	Nipple	Nippel	3/4"-3/4"
23	1	ST0 34 99-00	Rör, kpl.	Pipe, cpl.	Rohr, Kpl.	
24	2	63 79 74-01	Ångfälla	Steam trap	Kondensfalle	
25	1	ST0 34 98-00	Rör, kpl.	Pipe, cpl.	Rohr, Kpl.	
26	2	ST0 34 94-00	Fäste	Attachment	Befestigung	
27	1	ST0 35 00-00	Rör, kpl.	Pipe, cpl.	Rohr, Kpl.	
28	1	ST0 35 01-00	Rör, kpl.	Pipe, cpl.	Rohr, Kpl.	
29	1	ST0 35 02-00	Rör, kpl.	Pipe, cpl.	Rohr, Kpl.	
30	1	ST0 35 03-00	Rör, kpl.	Pipe, cpl.	Rohr, Kpl.	
31	1	741 21 15-20	Muff	Sleeve	Stutzen	3/4"
32	1	478 08 64-01	Termistor	Thermistor	Termistor	

Fet stil = Ändring

Bold print = Change

Fettdruck = Änderung

1). Vänstermatad maskin / Left hand side fed machine / Maschine mit Linkszuführung

2). Högermatad maskin / Right hand side fed machine / Maschine mit Rechtszuführung

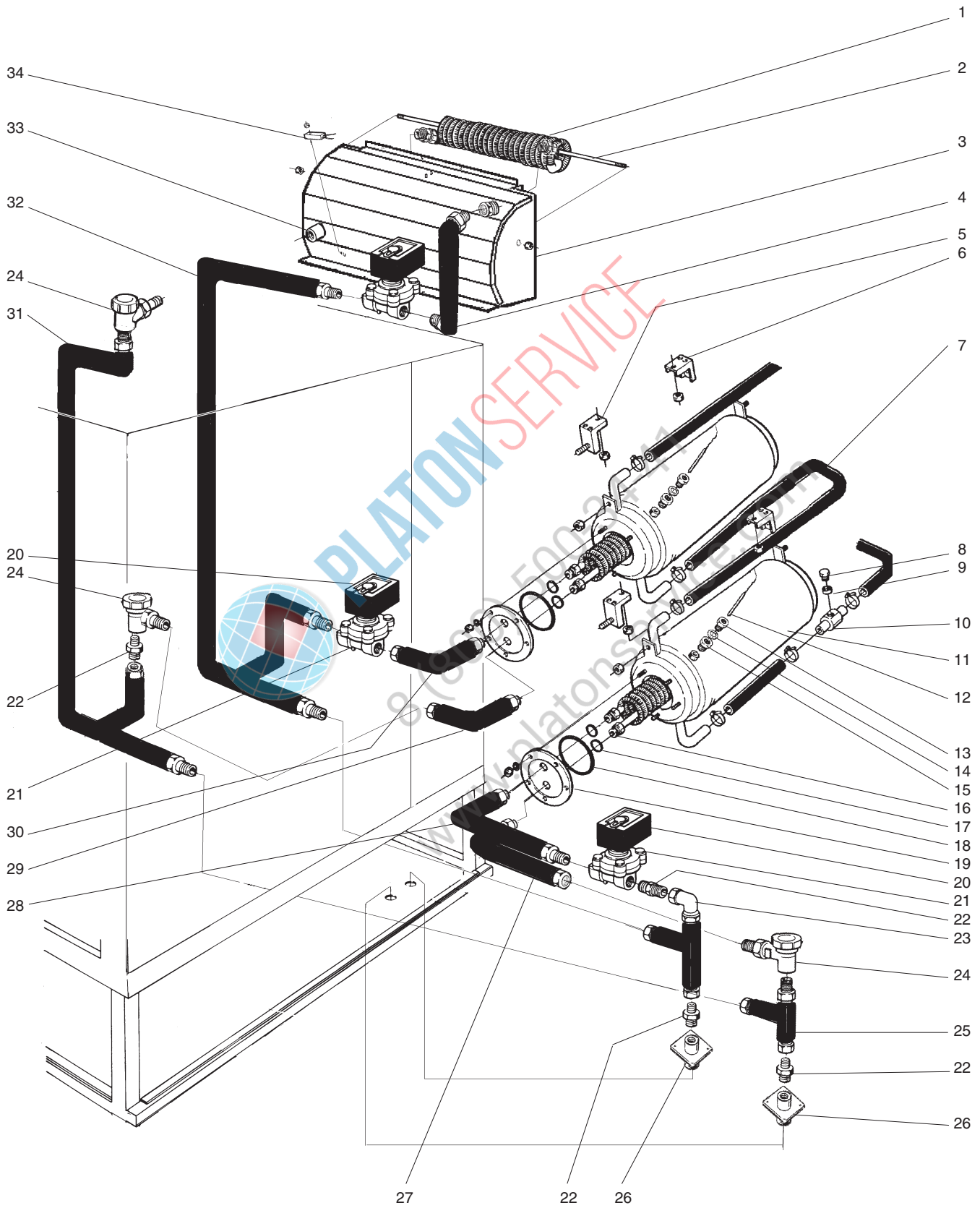

ILLUSTRATION 217 00

Tork, Genomströmmare, ånguppvärmd, Dubbel Drying tunnel, Booster, steam heated, Dubble Trockenzone, Durclauerhitzer, Dampfbeheizt Dubbel				Illustration 21700		Utgåva Edition Ausgabe 2	Månad Month Monat 08	År Year Jahr 2007
Pos.	Antal Quantity Anzahl	Art.nr Art. no Art. Nr	Benämning	Description	Bezeichnung	Anm. Notes Anm.		
1	1	ST0 31 35-00	Ångslinga	Steam coil	Dampfschleife	1).		
	1	ST0 31 35-01	Ångslinga	Steam coil	Dampfschleife	2).		
2	1	ST0 37 20-00	Stång	Bar	Stange			
3	1	ST0 31 37-00	Anslutningskåpa	Element cape	Elementgehäusen	1).		
	1	ST0 31 37-01	Anslutningskåpa	Element cape	Elementgehäusen	2).		
4	1	ST0 34 97-00	Rör, kpl.	Pipe, cpl.	Rohr, Kpl.	1).		
	1	ST0 34 97-01	Rör, kpl.	Pipe, cpl.	Rohr, Kpl.	2).		
5	2	482 68 56-00	Fäste	Attachment	Befestigung			
6	2	482 68 57-00	Fäste	Attachment	Befestigung			
7	x	552 00 13-00	Slang	Hose	Schlauch			
8	1	741 52 09-24	Plugg	Plug	Stöpsel	1/8"		
9	1	552 21 10-00	Packning	Gasket	Dichtung			
10	1	552 21 39-00	Anslutningsnippel	Connection nipple	Anslusnippel			
11	2	ST0 34 44-00	Genomströmmare, kpl.	Booster, cpl.	Durchlauferhitzer, Kpl.			
12	2	428 15 27-00	Termistor	Thermistor	Termistor			
13	1	478 04 46-00	Förskrivning	Pipe nipple	Verschraubung			
14	2	740 43 03-14	O-ring	O-ring	O-ring	5,3-2,4		
15	2	482 63 02-00	Bussning	Bush	Buchse			
16	2	491 35 44-00	Ångslinga	Steam coil	Dampfschleife			
17	4	552 21 10-03	Packning	Gasket	Dichtung			
18	2	477 74 08-00	O-ring	O-ring	O-Ring			
19	2	482 56 80-00	Fläns	Flange	Flansch			
20	3	463 97 00-00	Kabelhuvud	Cable terminal	Kabelschluß			
21	3	482 17 40-03	Magnetventil	Solenoid valve	Magnetventil	50 Hz		
	3	482 17 40-06	Magnetventil	Solenoid valve	Magnetventil	60 Hz		
22	4	741 31 15-22	Nippel	Nipple	Nippel	3/4"-3/4"		
23	1	ST0 34 99-00	Rör, kpl.	Pipe, cpl.	Rohr, Kpl.			
24	3	63 79 74-01	Ångfälla	Steam trap	Kondensfalle			
25	1	ST0 34 98-00	Rör, kpl.	Pipe, cpl.	Rohr, Kpl.			
26	2	ST0 34 94-00	Fäste	Attachment	Befestigung			
27	1	ST0 35 00-00	Rör, kpl.	Pipe, cpl.	Rohr, Kpl.			
28	1	ST0 35 01-00	Rör, kpl.	Pipe, cpl.	Rohr, Kpl.			
29	1	ST0 37 21-00	Rör, kpl.	Pipe, cpl.	Rohr, Kpl.			
30	1	ST0 37 22-00	Rör, kpl.	Pipe, cpl.	Rohr, Kpl.			
31	1	ST0 37 23-00	Rör, kpl.	Pipe, cpl.	Rohr, Kpl.	2).		
	1	ST0 37 23-01	Rör, kpl.	Pipe, cpl.	Rohr, Kpl.	1).		
32	1	ST0 37 24-00	Rör, kpl.	Pipe, cpl.	Rohr, Kpl.	2).		
	1	ST0 37 24-01	Rör, kpl.	Pipe, cpl.	Rohr, Kpl.	1).		
33	1	741 21 15-20	Muff	Sleeve	Stutzen	3/4"		
34	1	478 08 64-01	Termistor	Thermistor	Termistor			

Fet stil = Ändring
Bold print = Change
Fettdruck = Änderung

- 1). Vänstermatad maskin / Left hand side fed machine / Maschine mit Linkszuführung
2). Högermatad maskin / Right hand side fed machine / Maschine mit Rechtszuführung

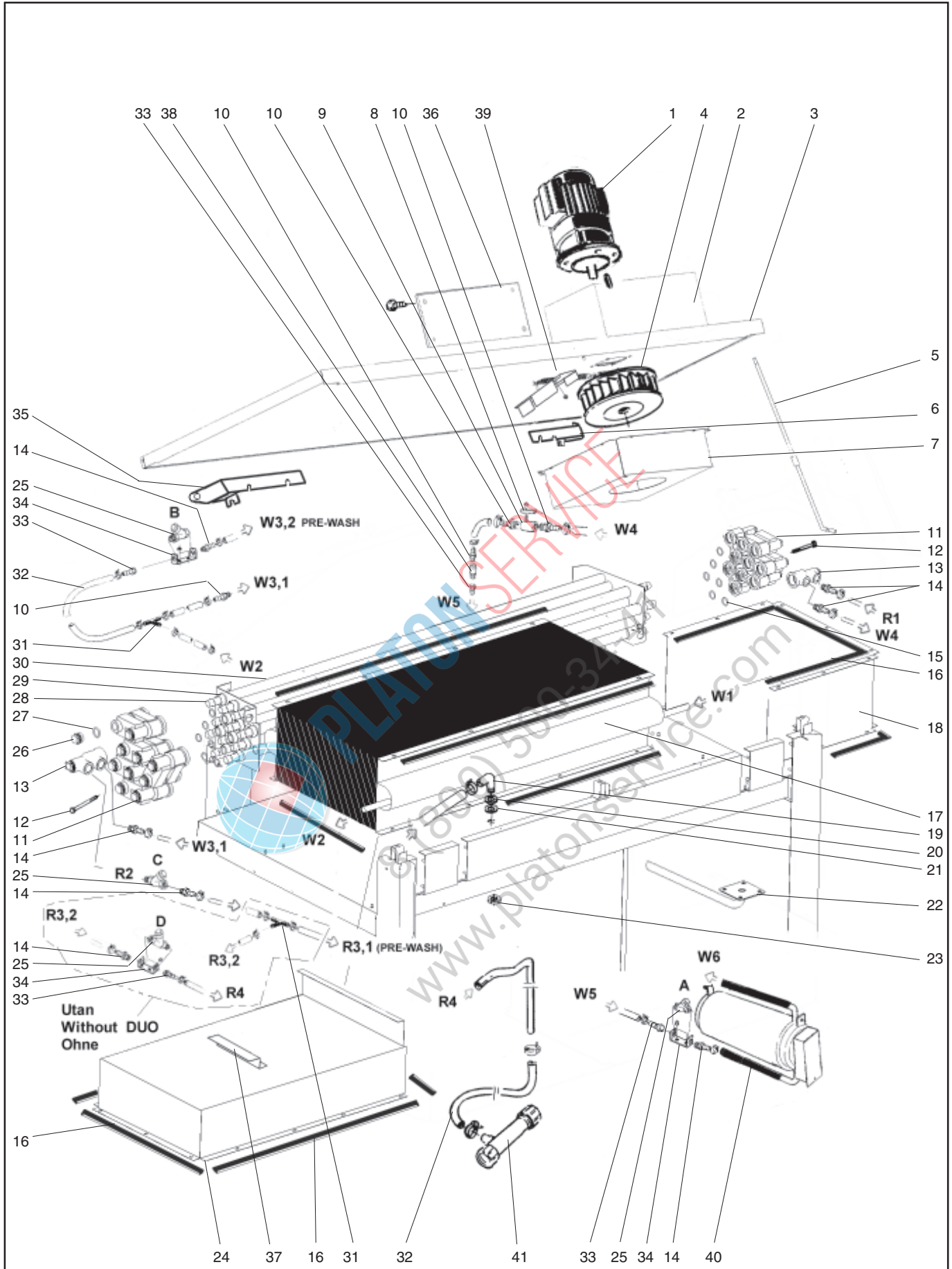

ILLUSTRATION 21697

Energipaket, ESD Energy saving device, ESD Wärmerückgewinnung, ESD			Illustration 21697			Utgåva Edition Ausgabe 4	Månad Month Monat 03	År Year Jahr 2007
Pos.	Antal Quantity Anzahl	Art.nr Art. no Art. Nr	Benämning	Description	Bezeichnung	Anm. Notes Anm.		
1	1	611 61 96-01	Fläktotor	Fan motor	Gebläsemotor			
2	1	ST0 26 93-00	Motorkåpa	Motor hood	motor Haube			
3	1	ST0 26 99-00	Tak	Top cover	Dach			1).
	1	ST0 26 99-01	Tak	Top cover	Dach			2).
4	1	549 64 18-00	Fläkt	Fan	Gebläse			
5	1	ST0 31 14-00	Stag, tak	Support, top cover	Stutze, Dach			
6	1	ST0 31 86-00	Gångjärn	Hinge	Scharnier			
7	1	ST0 26 90-00	Tryckkammare	Pressure chamber	Druckraum			
8	1	478 08 64-01	Termistor	Thermistor	Thermistor			
9	1	428 06 93-01	Infästning	Attachment	Befestigung			
10	4	552 21 75-00	Plastnippel	Nipple, plastic	Nippel, plastik			
11	10	478 03 32-00	Koppl.huvud	Coupl.housing	Kuppl.häuse			
12	10	725 24 69-40	Skruv	Screw	Schraube			M6S 8x90
13	2	478 03 33-00	Koppl.huvud	Coupl.housing	Kuppl.häuse			
14	3	552 21 71-00	Slangnippel, vinkel	Hose nipple, angular	Schlauchnippel, vinkel			6). 15x1/2"
	7	552 21 40-21	Slangnippel, rak	Hose nipple, angular	Schlauchnippel, gerade			6). 8). 15x1/2"
	5	552 21 40-21	Slangnippel, rak	Hose nipple, angular	Schlauchnippel, gerade			7). 8). 15x1/2"
15	44	740 43 15-14	O-ring	O-ring	O-ring			
16	x	87 33 03-241	Tätningband	Sealing ribbon	Dichtungsband			
17	1	ST0 26 85-00	Lamellelement	Element	Lamellelement			
18	1	ST0 26 89-00	Gavel ESD utsug	Side ESD exhaust duct	Side ESD absaugekanal			
19	x	ST0 44 85-00	Slangnippel, vinkel	Hose nipple, angular	Schlauchnippel, vinkel			12x1/2"
20	x	734 11 92-09	Bricka	Washer	Scheibe			3x21x37
21	x	552 21 10-03	Packning	Gasket	Dichtung			1/2"
22	1	ST0 34 46-00	Dränering, ESD	Drain, ESD	Drainierung, ESD			
23	x	741 11 13-24	Rörmutter	Pipe nut	Rohrmutter			1/2"
24	1	ST0 34 84-00	Gavel ESD paket	Side ESD box	Side ESD Kiste			3).
	1	ST0 34 85-00	Gavel ESD paket	Side ESD box	Side ESD Kiste			4).
	1	ST0 34 86-00	Gavel ESD paket	Side ESD box	Side ESD Kiste			5).
25	3	ST0 28 92-00	Radiatkoppling	Radiator filler neck	Radiatoranschluss			6).
	4	ST0 28 92-00	Radiatkoppling	Radiator filler neck	Radiatoranschluss			7). 8). 1/2"
26	22	478 04 29-03	Propp	Plug	Pfropfen			
27	22	478 03 03-00	O-ring	O-ring	O-ring			
28	11	ST0 26 97-00	Inre rör .	Inner tube	Innenrohr			
29	9	ST0 26 96-00	Yttre rör .	Outer tube	Aussenrohr			
30	1	ST0 28 78-00	ESD paket	ESD unit	ESD paket			
31	1	552 21 74-00	Slangnippel	Hose nipple	Schlauchnippel			6).
	2	552 21 74-00	Slangnippel	Hose nipple	Schlauchnippel			7). 8).
32	x	552 00 11-00	Slang	Hose	Schlauch			1/2"
33	3	ST0 28 57-00	Slangnippel	Hose nipple	Schlauchnippel			6).
	4	ST0 28 57-00	Slangnippel	Hose nipple	Schlauchnippel			7). 8). 15x1/2"
			1). Vänstermatad	Left feeded	Links Richtung			
			2). Högermatad	Right feeded	Rechts Richtung			
			3). WTF2					
			4). WTF3					
			5). WTF4					
			6). Med DUO	With DUO	Mit DUO			
			7). Utan DUO	Without DUO	Ohne DUO			
			8). Fr.o.m 2004, vecka 40	from 2004, Week 40	Ab. 2004, wochen 40			
			Fet stil = Ändring					
			Bold print = Change					
			Fettdruck = Änderung					

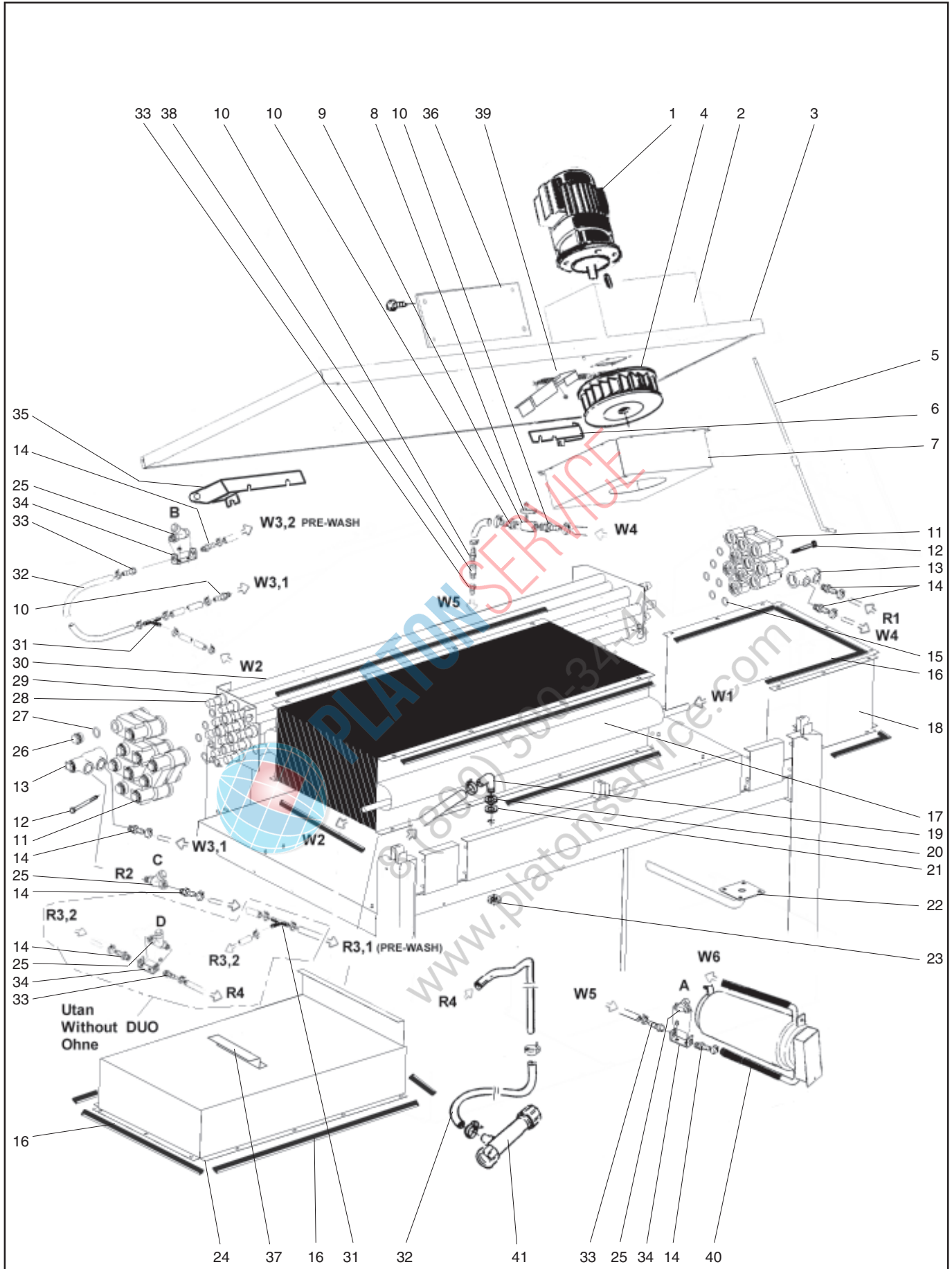

ILLUSTRATION 21697

Energipaket, ESD
Energy saving device, ESD
Wärmerückgewinnung, ESD

Illustration 21697

Utgåva
Edition
Ausgabe
4

Månad
Month
Monat
03

År
Year
Jahr
2007

Pos.	Antal Quantity Anzahl	Art.nr Art. no Art. Nr	Benämning	Description	Bezeichnung	Anm. Notes Anm.
34	2	482 68 92-00	Fäste	Attachment	Befestigung	6).
	2	482 68 92-00	Fäste	Attachment	Befestigung	7). 8).
35	1	ST0 31 86-01	Gångjärn	Hinge	Scharnier	
36	1	ST0 26 94-00	Täckplåt motorkåpa	Cover motor hood	Deckplatte Motor Haube	
37	1	ST0 31 89-01	Takstöd	Top support	Deck stütze	3).
	2	ST0 31 89-01	Takstöd	Top support	Deck stütze	4).
	3	ST0 31 89-01	Takstöd	Top support	Deck stütze	5).
38	1	482 95 27-00	Säkerhetskombination	Safty combination	Sicherheitskombinazion	
39	1	ST0 26 91-00	Stänkskydd	Splash guard	Spritzschutz	7).
40	x	552 0013-00	Slang	Hose	Schlauch	
41	1	ST0 39 39-00	Avloppsdel	Drainn part	Ablaufrohr	7).



PLATON SERVICE

8 (800) 500-34-47

www.platonservice.com

- 1). Vänstermatad
- 2). Högermatad
- 3). WTF2
- 4). WTF3
- 5). WTF4
- 6). Med DUO
- 7). Utan DUO
- 8). Fr.o.m 2004, vecka 40

- Left feeded
Right feeded
- With DUO
Without DUO
from 2004, Week 40

- Links Richtung
Rechts Richtung
- Mit DUO
Ohne DUO
Ab. 2004, wochen 40

Fet stil = Ändring
Bold print = Change
Fettdruck = Änderung

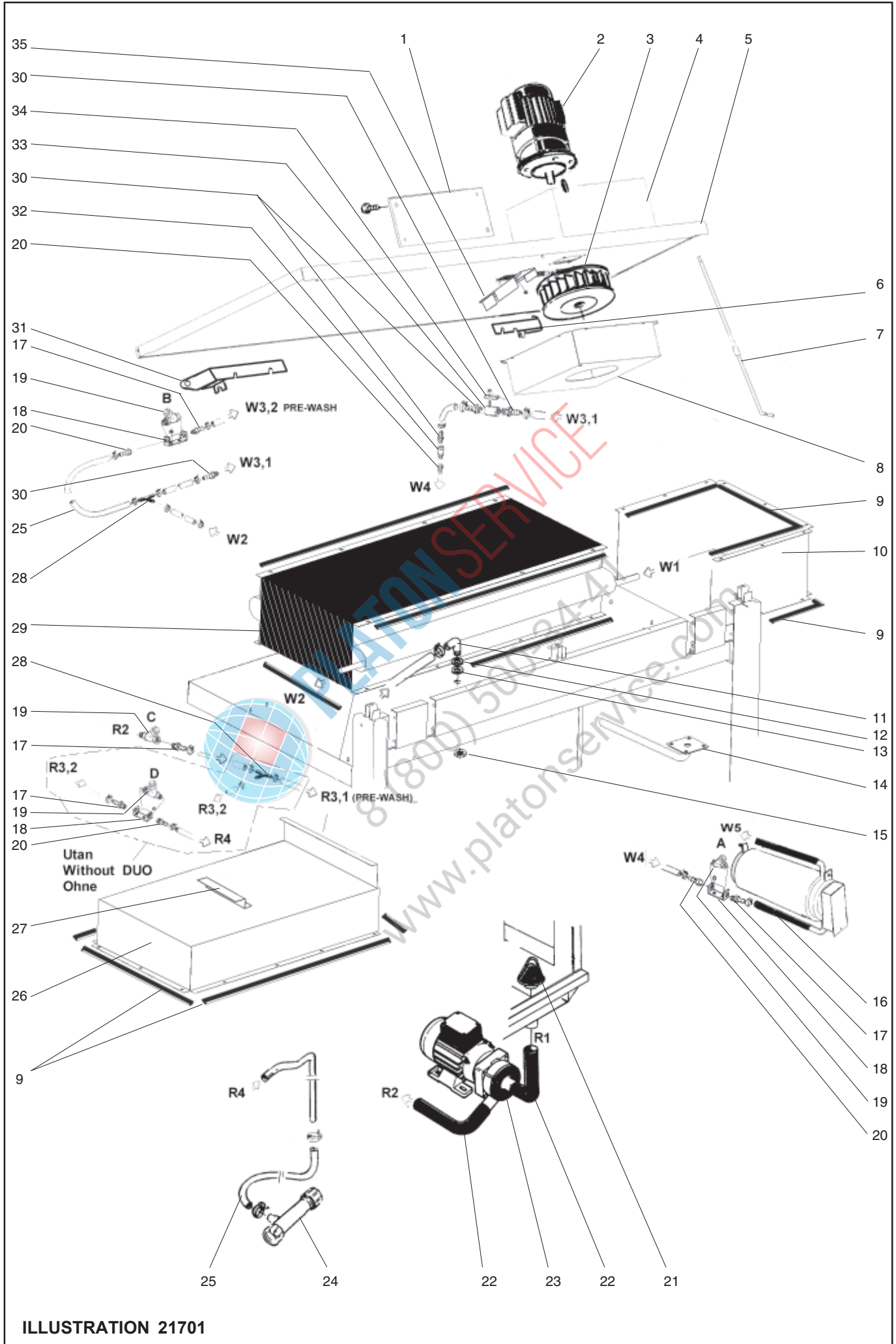

ILLUSTRATION 21701

Kondensanläggning, CU Condensing unit, CU Kondensationanlage, CU			Illustration 21701			Utgåva Edition Ausgabe 1	Månad Month Monat 09	År Year Jahr 2007
Pos.	Antal Quantity Anzahl	Art.nr Art. no Art. Nr	Benämning	Description	Bezeichnung	Anm. Notes Anm.		
1	1	ST0 26 94-00	Täckplåt motorkåpa	Cover motor hood	Deckplatte Motor Haube			
2	1	611 61 96-01	Fläktotor	Fan motor	Gebläsemotor			
3	1	549 64 18-00	Fläkt	Fan	Gebläse			
4	1	ST0 26 93-00	Motorkåpa	Motor hood	motor Haube			
5	1	ST0 26 99-00	Tak	Top cover	Dach	1).		
	1	ST0 26 99-01	Tak	Top cover	Dach	2).		
6	1	ST0 31 86-00	Gångjärn	Hinge	Scharnier			
7	1	ST0 31 14-00	Stag, tak	Support, top cover	Stutze, Dach			
8	1	ST0 26 90-00	Tryckkammare	Pressure chamber	Druckraum			
9	x	87 33 03-241	Tätningband	Sealing ribbon	Dichtungsband			
10	1	ST0 26 89-00	Gavel ESD utsug	Side ESD exhaust duct	Side ESD absaugekanal			
11	x	ST0 44 85-00	Slangnippel, vinkel	Hose nipple, angular	Schlauchnippel, vinkel			12x1/2"
12	x	734 11 92-09	Bricka	Washer	Scheibe	3x21x37		
13	x	552 21 10-03	Packning	Gasket	Dichtung	1/2"		
14	1	ST0 34 46-00	Dränering, ESD	Drain, ESD	Drainierung, ESD			
15	x	741 11 13-24	Rörmutter	Pipe nut	Rohrmutter	1/2"		
16	x	552 0013-00	Slang	Hose	Schlauch			
17	3	552 21 71-00	Slangnippel, vinkel	Hose nipple, angular	Schlauchnippel, vinkel	6).		15x1/2"
	7	552 21 40-21	Slangnippel, rak	Hose nipple, angular	Schlauchnippel, gerade	6).		15x1/2"
	5	552 21 40-21	Slangnippel, rak	Hose nipple, angular	Schlauchnippel, gerade	7).		15x1/2"
18	2	482 68 92-00	Fäste	Attachment	Befestigung	6).		
	2	482 68 92-00	Fäste	Attachment	Befestigung	7).		
19	3	ST0 28 92-00	Radiatorkoppling	Radiator filler neck	Radiatoranschluss	6).		1/2"
	4	ST0 28 92-00	Radiatorkoppling	Radiator filler neck	Radiatoranschluss	7).		1/2"
20	3	ST0 28 57-00	Slangnippel	Hose nipple	Schlauchnippel	6).		15x1/2"
	4	ST0 28 57-00	Slangnippel	Hose nipple	Schlauchnippel	7).		15x1/2"
21	1	477 90 36-00	Finsil	Strainer	Sieb			
	1	482 42 79-00	Kedja	Chain	Ketten			
22	2	478 08 71-00	Slang	Hose	Schlauch			
23	1	482 77 21-00	Pump	Pump	Pumpe	230 / 400V, 50 Hz		
	1	482 77 21-02	Pump	Pump	Pumpe	230 / 400V, 60 Hz		
		482 77 21-10	Pumphus	Pump housing	Pumpengehäuse			
		482 77 21-11	Packning	Gasket	Dichtung			
		482 77 21-12	Pumphjul	Impeller	Pumpenrad			
24	1	ST0 39 39-00	Avloppsdel	Drain part	Ablaufrohr	7).		
25	x	552 00 11-00	Slang	Hose	Schlauch	1/2"		
26	1	ST0 34 84-00	Gavel ESD paket	Side ESD box	Side ESD Kiste	3).		
	1	ST0 34 85-00	Gavel ESD paket	Side ESD box	Side ESD Kiste	4).		
	1	ST0 34 86-00	Gavel ESD paket	Side ESD box	Side ESD Kiste	5).		
27	1	ST0 31 89-01	Takstöd	Top support	Deck stütze	3).		
	2	ST0 31 89-01	Takstöd	Top support	Deck stütze	4).		
	3	ST0 31 89-01	Takstöd	Top support	Deck stütze	5).		
			1). Vänstermatad	Left feeded	Links Richtung			
			2). Högermatad	Right feeded	Rechts Richtung			
			3). WTF2					
			4). WTF3					
			5). WTF4					
			6). Med DUO	With DUO	Mit DUO			
			7). Utan DUO	Without DUO	Ohne DUO			
			Fet stil = Ändring					
			Bold print = Change					
			Fettdruck = Änderung					

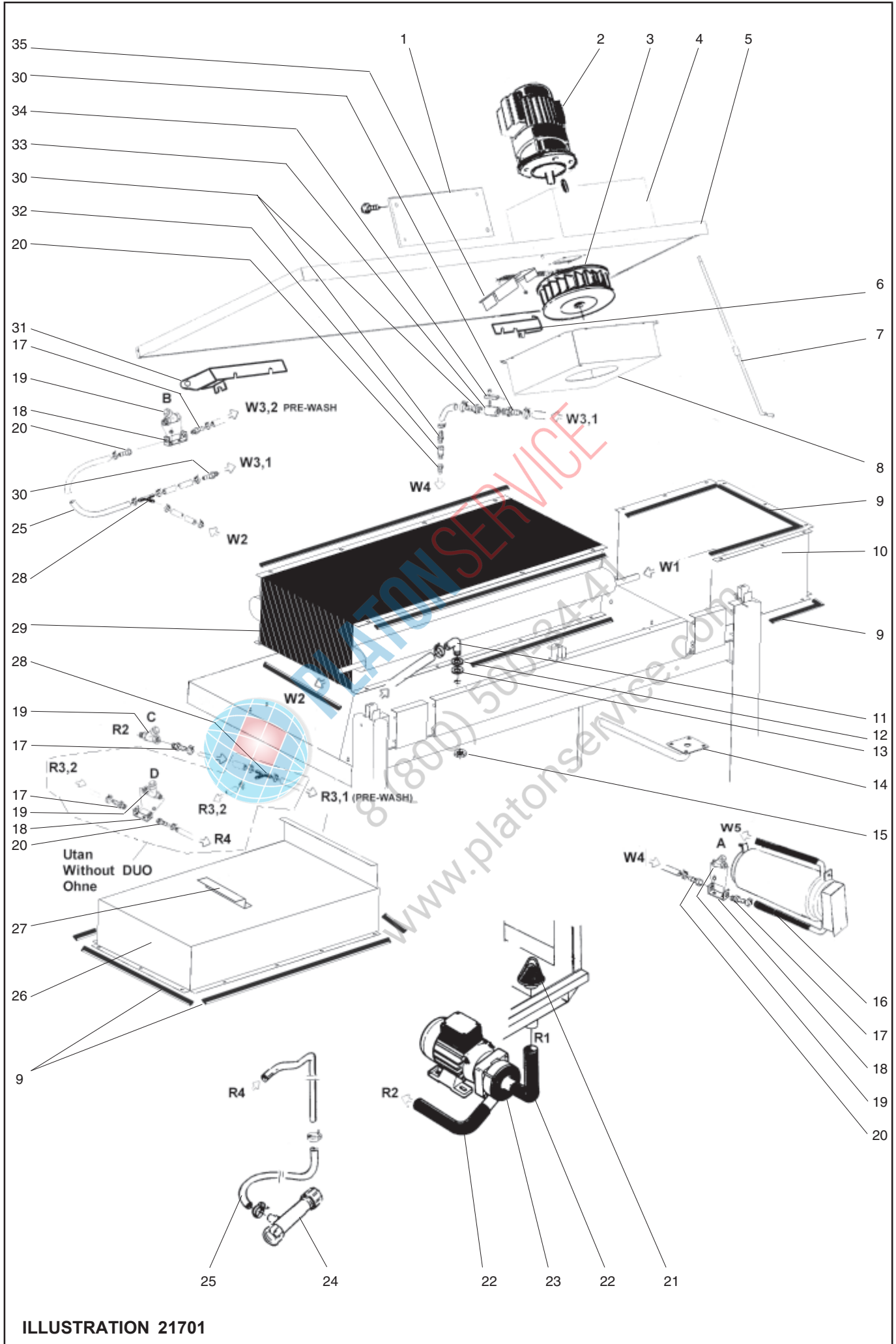

ILLUSTRATION 21701

Kondensanläggning, CU
Condensing unit, CU
Kondensationanlage, CU

Illustration 21701

Utgåva
Edition
Ausgabe
1

Månad
Month
Monat
09

År
Year
Jahr
2007

Pos.	Antal Quantity Anzahl	Art.nr Art. no Art. Nr	Benämning	Description	Bezeichnung	Anm. Notes Anm.
28	1	552 21 74-00	Slangnippel	Hose nipple	Schlauchnippel	6).
	2	552 21 74-00	Slangnippel	Hose nipple	Schlauchnippel	7).
29	1	ST0 26 85-00	Lamellelement	Element	Lamellelement	
30	4	552 21 75-00	Plastnippel	Nipple, plastic	Nippel, plastik	
31	1	ST0 31 86-01	Gångjärn	Hinge	Scharnier	
32	1	482 95 27-00	Säkerhetskombination	Safty combination	Sicherheitskombination	
33	1	428 06 93-01	Infästning	Attachment	Befestigung	
34	1	478 08 64-01	Termistor	Thermistor	Thermistor	
35	1	ST0 26 91-00	Stänkydd	Splash guard	Spritzschutz	7).



PLATON SERVICE

8 (800) 500-34-47

www.platonservice.com

- 1). Vänstermatad
- 2). Högermatad
- 3). WTF2
- 4). WTF3
- 5). WTF4
- 6). Med DUO
- 7). Utan DUO

Left feeded
Right feeded

With DUO
Without DUO

Links Richtung
Rechts Richtung

Mit DUO
Ohne DUO

Fet stil = Ändring
Bold print = Change
Fettdruck = Änderung

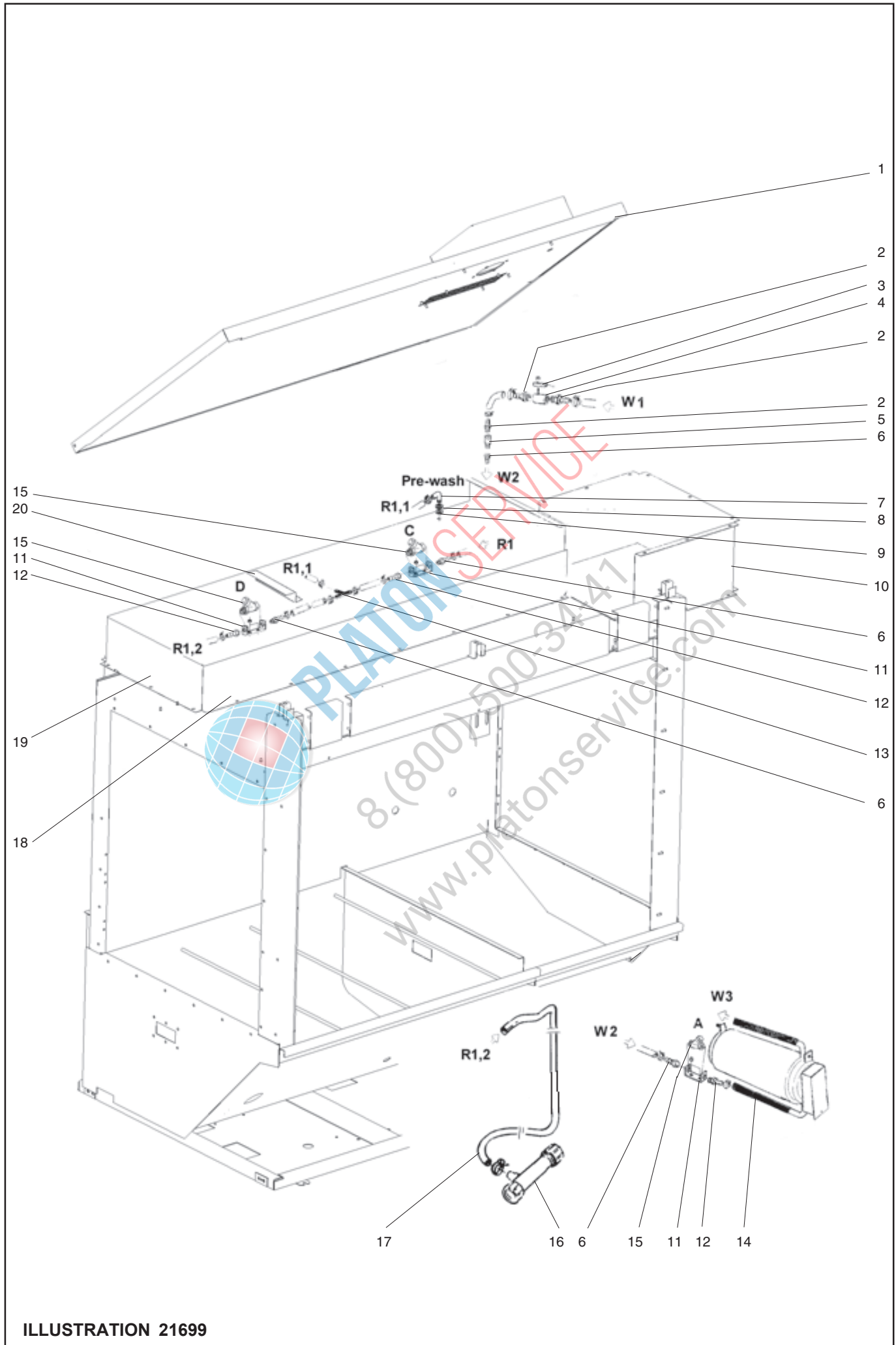

ILLUSTRATION 21699

Slangar, utan ESD/ CU Hoses, without ESD/ CU Schlauches, ohne ESD/ CU			Illustration 21699			Utgåva Edition Ausgabe 2	Månad Month Monat 09	År Year Jahr 2007
Pos.	Antal Quantity Anzahl	Art.nr Art. no Art. Nr	Benämning	Description	Bezeichnung	Anm. Notes Anm.		
1	1	ST0 31 43-00	Tak	Top cover	Dach	1).		
	1	ST0 31 43-01	Tak	Top cover	Dach	2).		
2	3	552 21 75-00	Plastnippel	Nipple, plastic	Nippel, plastik			
3	1	478 08 64-01	Termistor	Thermistor	Thermistor			
4	1	428 06 93-01	Infästning	Attachment	Befestigung			
5	1	482 95 27-00	Säkerhetskombination	Safety combination	Sicherheitskombination			
6	3	ST0 28 57-00	Slangnippel	Hose nipple	Schlauchnippel	6). 15x1/2"		
	4	ST0 28 57-00	Slangnippel	Hose nipple	Schlauchnippel	7). 8). 15x1/2"		
7	1	552 21 73-00	Slangnippel	Hose nipple	Schlauchnippel			
8	1	734 11 92-09	Bricka	Washer	Scheibe	21x37x3		
9	1	552 21 10-03	Packning	Gasket	Dichtung	1/2"		
10	1	ST0 31 33-00	Kanal undre	Chanel lower	Kanal unter	3).		
	1	ST0 34 59-00	Kanal undre	Chanel lower	Kanal unter	4).		
	1	ST0 34 59-01	Kanal undre	Chanel lower	Kanal unter	5).		
	1	ST0 34 61-00	Kanal undre	Chanel lower	Kanal unter	5).		
11	2	482 68 92-00	Fäste	Attachment	Befestigung	6).		
	3	482 68 92-00	Fäste	Attachment	Befestigung	7). 8).		
12	2	552 21 71-00	Slangnippel	Hose nipple	Schlauchnippel	6). 15x1/2"		
	3	552 21 71-00	Slangnippel	Hose nipple	Schlauchnippel	7). 8). 15x1/2"		
13	1	552 21 74-00	Slangnippel, T	Hose nipple, T	Schlauchnippel, T	7). 8). 15x1		
14	x	552 00 13-00	Slang	Hose	Schlauch			
15	2	ST0 28 92-00	Radiatekoppling	Radiator filler neck	Radiatoranschluss	7). 8). 1/2"		
	3	ST0 28 92-00	Radiatekoppling	Radiator filler neck	Radiatoranschluss	6). 1/2"		
16	1	ST0 39 39-00	Avloppsdel	Drain part	Ablaufrohr	7). 8).		
17	x	552 00 11-00	Slang	Hose	Schlauch	7). 8). 1/2"		
18	1	ST0 31 32-00	Kanal övre	Chanel upper	Kanal ubere	3).		
	1	ST0 34 58-00	Kanal övre	Chanel upper	Kanal ubere	4).		
	1	ST0 34 60-01	Kanal övre	Chanel upper	Kanal ubere	5).		
19	1	ST0 34 60-02	Gavel plåt	Side plate	Side plate	5).		
20	1	ST0 31 89-02	Takstöd	Top support	Deck stütze	3).		
	2	ST0 31 89-02	Takstöd	Top support	Deck stütze	4).		
	3	ST0 31 89-03	Takstöd	Top support	Deck stütze	5).		

1). Vänstermatad

Left feeded

Links Richtung

2). Högermatad

Right feeded

Rechts Richtung

3). WTF2

4). WTF3

5). WTF4

Fet stil = Ändring

Bold print = Change

Fettdruck = Änderung

6). Med DUO

With DUO

Mit DUO

7). Utan DUO

Without DUO

Ohne DUO

8). Fr.o.m 2004, vecka 40

from 2004, Week 40

Ab. 2004, wochen 40

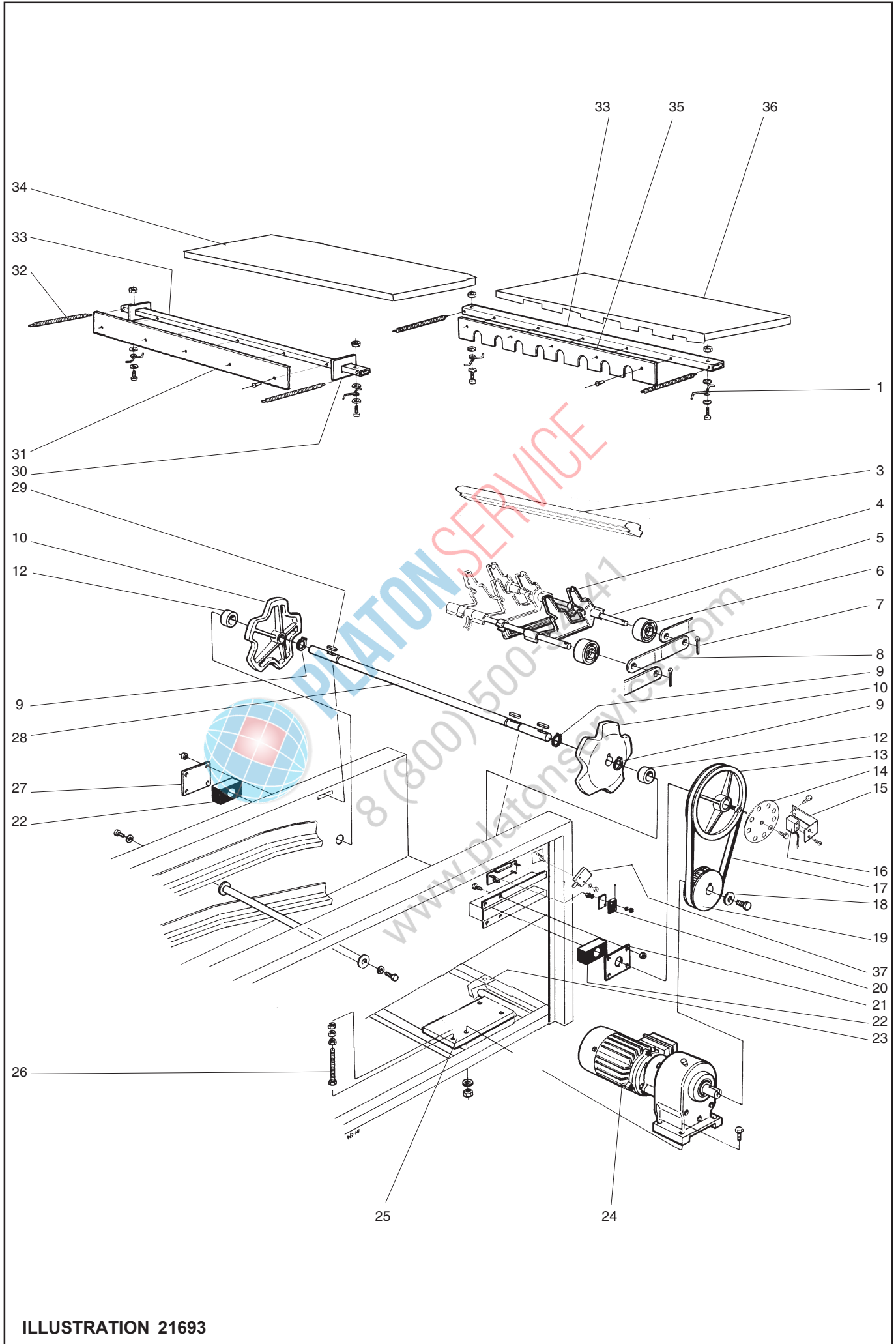

ILLUSTRATION 21693

Transportband-driving Feeding Zuführung		Illustration 21693				Utgåva Edition Ausgabe 4	Månad Month Monat 09	År Year Jahr 2007
Pos.	Antal Quantity Anzahl	Art.nr Art. no Art. Nr	Benämning	Description	Bezeichnung	Anm. Notes Anm.		
1	2	481 98 75-00	Fjäder	Spring	Feder			
3	X	482 19 72-00	Stödpinne (blå)	Supporting bar (blue)	Stützleiste (Blau)			
4	X	482 38 30-00	Fingerlänk	Finger link	Fingerlasche	1).		
	X	482 19 10-00	Fingerlänk	Finger link	Fingerlasche	2).		
	X	428 08 33-00	Inflight fingerlänk	Inflight Finger link	InflightFingerlasche	1).		
	X	428 08 34-00	Medbringarfingerlänk	Carrier Finger link	Mitnehmer Fingerlasche	1).		
5	X	490 17 58-00	Axel	Shaft	Achse			
6	X	482 62 43-00	Rulle	Pulley	Rolle			
7	X	721 61 50-40	Saxpinne 2x12	Dowel 2x12	Splint 2x12			
8	X	482 44 11-00	Ytterlänk	Outer link	Aussenlasche	1).		
	X	482 44 13-00	Ytterlänk	Outer link	Aussenlasche	2).		
9	3	735 31 22-07	Spårring	C-clamp	Schlitzring	Sga20		
10	2	464 36 78-02	Tandhjul	Cog wheel	Zahnrad	1).		
	2	482 22 61-00	Tandhjul	Cog wheel	Zahnrad	2).		
12	2	428 06 95-00	Distans	Distance	Distanz			
13	1	467 60 78-02	Drivhjul	Drive gear	Triebrad			
14	1	ST0 27 83-00	Pulsrondell	Pulse generating disk	Pulsrondell			
15	1	ST0 27 84-00	Givarfäste	Attachment	Befestigung			
16	1	428 06 89-00	Pulsräknare, induktiv	Pulse counter inductive	Puls rechner inductiv			
17	1	461 04 43-11	Kuggrem	Toothed belt	Riemen	WTF4		
	1	461 04 43-03	Kuggrem	Toothed belt	Riemen	WTF3		
	1	461 04 43-04	Kuggrem	Toothed belt	Riemen	WTF2		
18	1	53 92 88-53	Bricka	Washer	Scheibe			
19	1	461 04 44-10	Kuggskiva	Toothed disc	Zahnscheibe	WTF4		
	1	461 04 44-09	Kuggskiva	Toothed disc	Zahnscheibe	WTF3		
	1	461 04 44-04	Kuggskiva	Toothed disc	Zahnscheibe	WTF2		
20	2	ST0 28 95-00	Mikrobrytare	Microswitch	Mikroschalter			
21	1	481 71 28-01	Lagerhållare	Bearing cage	Lagerhalterung			
22	2	481 72 83-00	Lagring	Bearing	Lagerung			
23	1	ST0 28 27-00	Fäste	Attachment				
24	1	490 14 59-00	Kuggväxelmotor	Worm Gear Motor	Getriebemotor	400V,50/60 Hz		
	1	490 14 59-02	Kuggväxelmotor	Worm Gear Motor	Getriebemotor	230V,50/60 Hz		
25	1	ST0 28 25-00	Motorkonsol	Motor bracket	Motorkonsole			
26	1	725 25 17-45	Skruv	Screw	Schraube	M6S 10x150		
27	1	481 71 28-00	Lagerhållare	Bearing cage	Lagerhalterung			
28	1	ST0 28 87-00	Axel	Shaft	Achse			
29	3	735 93 02-40	Kil	Wedge	Keil	8x7x36		
30	2	ST0 28 36-00	Glidklots	Protective stud	Gleitklotz			
31	1	ST0 34 15-00	Ändlägesskydd	Safeguard	Schutz	3).		
32	2	477 62 76-01	Fjäder	Spring	Feder			
33	1	ST0 28 35-00	Ändlägesstång	Bar	Stange			
34	1	ST0 34 23-00	Ändlägesplåt	End limit plate	Endschalterplate	3).		
35	1	ST0 30 18-00	Ändlägesskydd	Safeguard	Schutz	Standard		
36	1	ST0 28 29-00	Ändlägesplåt	End limit plate	Endschalterplate	Standard		
37	2	428 10 96-01	Gränslägesbrytare	End limit switch	Endschalter			

Fet stil = Ändring
Bold print = Change
Fettdruck = Änderung

1). Axelavstånd C-C=120mm
2). Axelavstånd C-C=100mm
3). Med blå stödpinne

Distance between shafts C-C= 120mm
Distance between shafts C-C= 100mm
With the blue supporting bar

Achsabstand C-C=120mm
Achsabstand C-C=100mm
mit blau Stützleiste

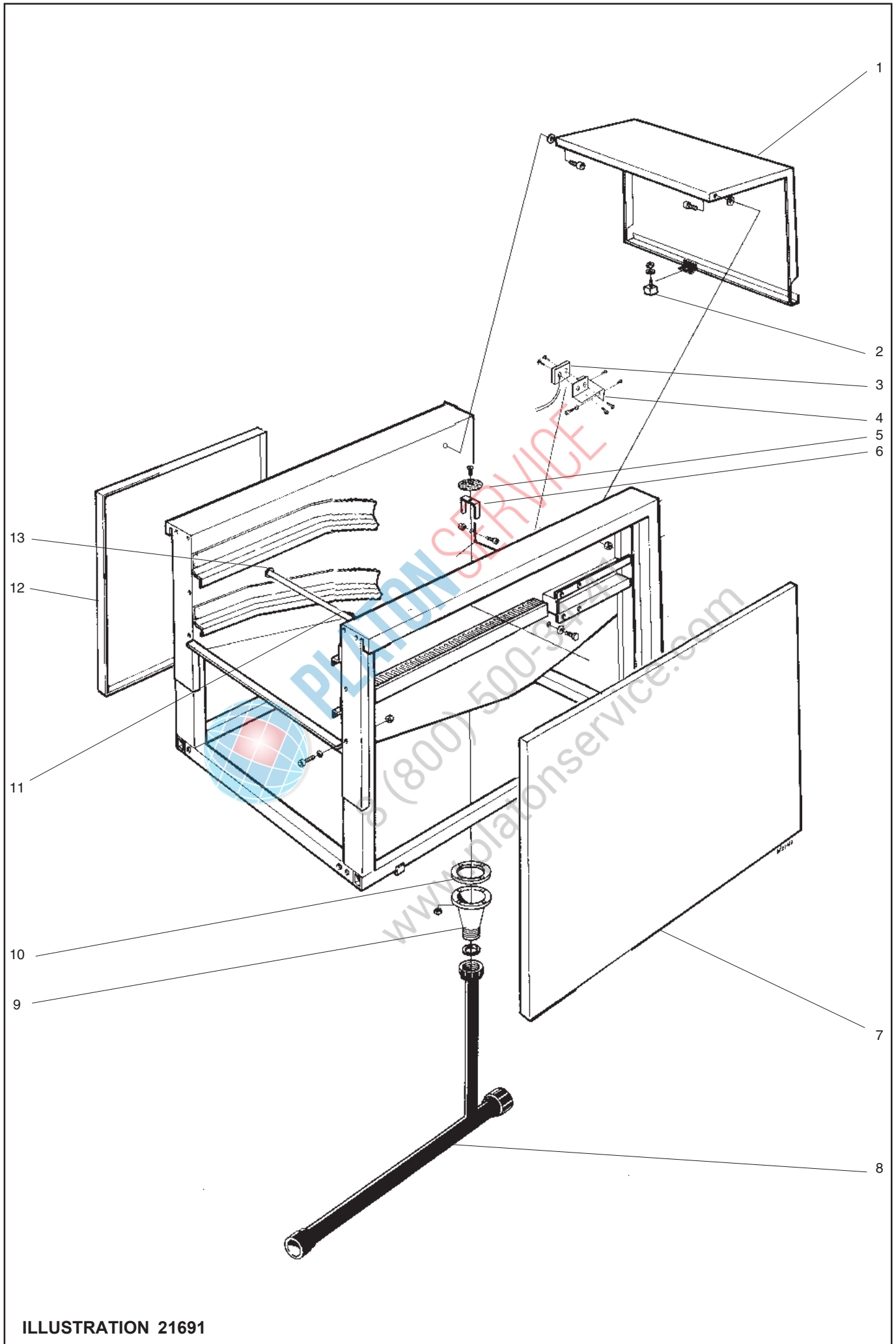

ILLUSTRATION 21691

Utmatning, L=700, 1100
 Unload section, L=700, 1100
 Auslaufstrecke, L=700, 1100

Illustration 21691

Utgåva
 Edition
 Ausgabe
 3

Månad
 Month
 Monat
 09

År
 Year
 Jahr
 2007

Pos.	Antal Quantity Anzahl	Art.nr Art. no Art. Nr	Benämning	Description	Bezeichnung	Anm. Notes Anm.
	[]		Utmatning, L=700 Utmatning, L=1100	Unload section, L=700 Unload section, L=1100	Auslaufstrecke, L=700 Auslaufstrecke, L=1100	
1	1	ST0 26 27-01	Gavellucka	Side unit	Seite	
2	1	461 13 78-02	Magnet	Magnet	Magnet	
3	1	476 06 64-01	Magnetbrytare	Magn.Cont.Switch	Magnetausschate	
4	1	491 38 74-00	Fäste	Attachement	Befestigung	
5	1	428 02 89-00	Sil	Strainer	Sieb	
6	1	481 71 88-00	Silstyrning	Holder	Halter	
7	2	ST0 26 47-00	Sida kpl.	Side	Seite kpl.	
	-	ST0 30 45-00	Sida kpl.	Side	Seite kpl.	
8	1	ST0 28 75-00	Avlopp	Drain	Ablauf	
	-	ST0 28 75-01	Avlopp	Drain	Ablauf	
9	1	475 77 84-00	Avloppsstos	Drain pipe conn.	Ablaufstutzen	
10	1	477 73 94-00	Packning	Gasket	Dichtung	
11	1	87 79 50-205	Kabelkanal	Canal passage	Kablekanal	
12	1	482 01 42-00	Distanstång	Bar	Stange	
13	2	53 92 88-32	Bricka	Washer	Schelbe	



PLATON SERVICE
 8 (800) 500-34-47
 www.platonservice.com

Fet stil = Ändring
 Bold print = Change
 Fettdruck = Änderung

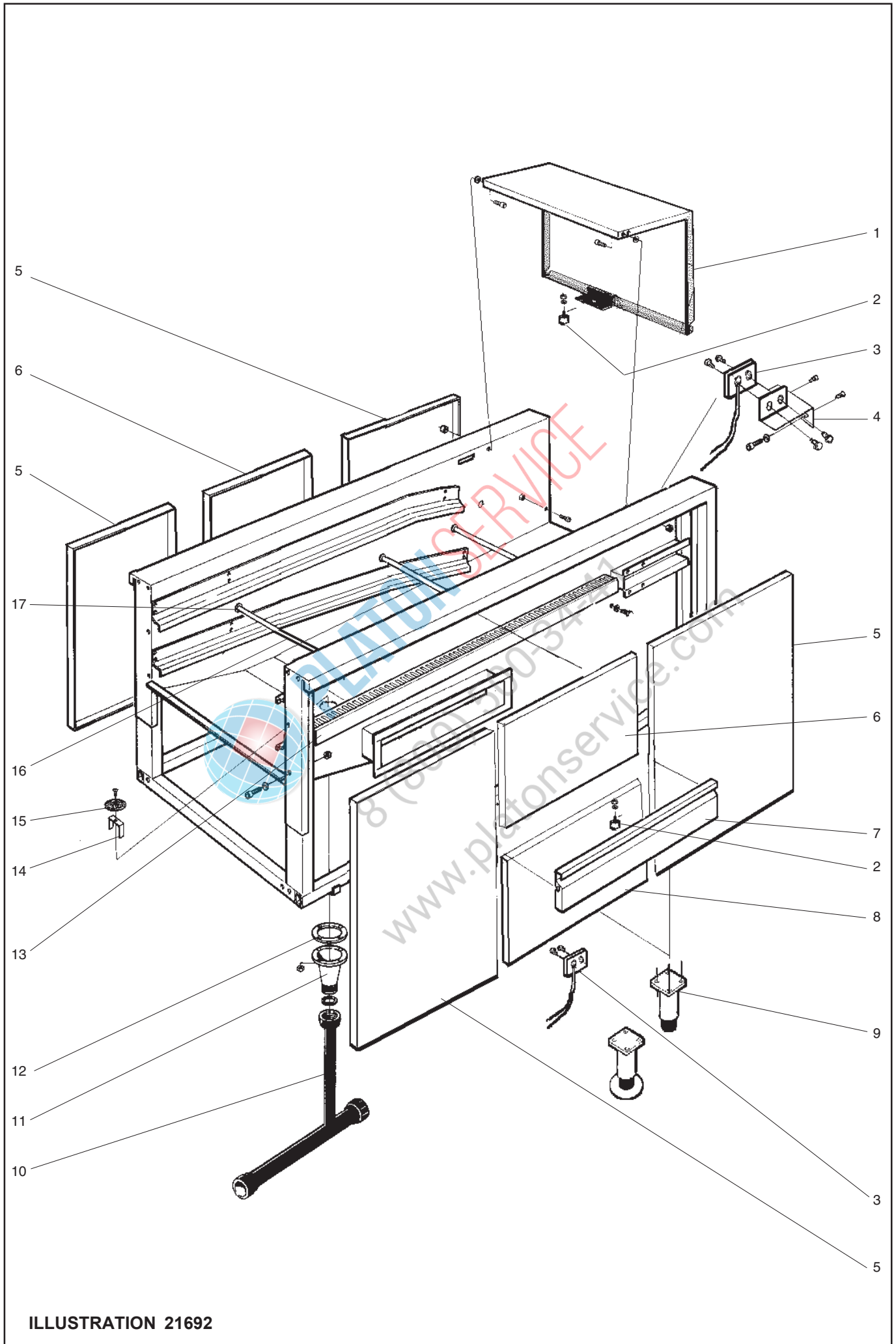

ILLUSTRATION 21692

Utmatning, L=1500
 Unload section, L=1500
 Auslaufstrecke, L=1500

Illustration 21692

Utgåva
 Edition
 Ausgabe
 3

Månad
 Month
 Monat
 09

År
 Year
 Jahr
 2007

Pos.	Antal Quantity Anzahl	Art.nr Art. no Art. Nr	Benämning	Description	Bezeichnung	Anm. Notes Anm.
1	1	ST0 26 27-01	Gavellucka	Side unit	Seite	
2	3	461 13 78-02	Magnet	Magnet	Magnet	
3	3	476 06 64-01	Magnetbrytare	Magn.Cont.Switch	Magnetausschate	
4	1	491 38 74-00	Fäste	Attachement	Befestigung	
5	4	ST0 31 08-00	Sida	Side	Seite	1).
	4	ST0 39 70-00	Sida	Side	Seite	2).
6	2	ST0 31 09-00	Sida, övre	Side, upper	Seite, uber	1).
	2	ST0 39 72-00	Sida, övre	Side, upper	Seite, uber	2).
7	2	ST0 32 75-00	Utmatningslucka	Side unit	Seite	
8	2	ST0 31 10-00	Sida, nedre	Side, lower	Seite, unter	1).
	2	ST0 39 73-00	Sida, nedre	Side, lower	Seite, unter	2).
9	2	855 64 90-00	Ben	Leg	Bein	
10	1	ST0 28 75-02	Avlopp	Drain	Ablauf	
11	1	475 77 84-00	Avloppsstos	Drain pipe conn.	Ablaufstutzen	
12	1	477 73 94-00	Packning	Gasket	Dichtung	
13	1	87 79 50-205	Kabelkanal	Canal passage	Kablekanal	
14	1	481 71 88-00	Silstyrning	Holder	Halter	
15	1	428 02 89-00	Sil	Strainer	Sieb	
16	2	482 01 42-00	Distansstång	Bar	Stange	
17	4	53 92 88-32	Bricka	Washer	Schelbe	



Fet stil = Ändring
 Bold print = Change
 Fettdruck = Änderung

1). T.o.m. 2005, Vecka 09
 2). Fr.o.m. 2005, Vecka 10

To 2005, week 09
 From 2005, week 10

Zu 2005, wochen 09
 Ab. 2005, wochen 10

Fästelement Attachment element Befestigungsteile				Utgåva Edition Ausgabe 3	Månad Month Monat 09	År Year Jahr 2007
Art.nr Art. no Art. Nr	Benämning	Description	Bezeichnung	Anm. Notes Anm.		
552 20 25-00 552 21 21-02	Korgmutter Flänsmutter	Cage nut Flange nut	Korbmutter Flanschmutter	M5 M5		
53 92 88-32 53 92 88-51 722 78 43-02	Bricka Bricka Popnit	Washer Washer Blind rivet	Scheibe Scheibe Popniete	BRB 6,4x38 RFR BRB 8,5x38 RFR 4x10,3		
732 31 14-40 732 31 16-40	Kupolmutter Mutter	Dome nut Nut	Kappenmutter Mutter	MHM 5 RFR MHM 6 RFR		
736 28 28-51 736 28 43-90 736 28 55-90	Slangklämma Slangklämma Slangklämma	Hose clamp Hose clip Hose clip	Schlauchklemme Schlauchschelle Schlauchschelle	Ø 38 Ø 75 Ø 138		
478 56 64-03 725 53 29-40	Skruv Skruv	Screw Screw	Schraube Schraube	LKCS 5x10 RFR MC6S 5x16 RFR		
725 54 51-40 728 83 21-09 728 84 47-09	Skruv Skruv Skruv	Screw Screw Screw	Schraube Schraube Schraube	MC6S 8x20 RFR SK6SS 5x6 RFR SK6SS 8x12 RFR		
734 11 24-09 734 11 36-09 734 48 84-40 734 11 46-09	Bricka Bricka Bricka Bricka	Washer Washer Washer Washer	Scheibe Scheibe Scheibe Scheibe	BRB 3,2x7 RFR BRB 4,3x9 RFR BRB 5,2x15 RFR BRB 5,3x10 RFR		
734 49 17-40 734 11 64-09 734 11 73-09	Bricka Bricka Bricka	Washer Washer Washer	Scheibe Scheibe Scheibe	BRB 6,5x16 RFR BRB 8,4x25 RFR BRB 10,5x21 RFR		
734 11 78-09 724 12 28-40	Bricka Skruv	Washer Screw	Scheibe Schraube	BRB 13x24 RFR MRX 3x16 RFR		
724 12 89-40 724 12 92-40 724 13 23-40	Skruv Skruv Skruv	Screw Screw Screw	Schraube Schraube Schraube	MRX 4x10 RFR MRX 4x14 RFR MRX 5x8 RFR		
724 13 31-40 725 23 27-40 725 23 31-40	Skruv Skruv Skruv	Screw Screw Screw	Schraube Schraube Schraube	MRX 5x20 RFR M6S 5x12 RFR M6S 5x20 RFR		
725 23 66-40 725 23 70-40 725 23 78-40	Skruv Skruv Skruv	Screw Screw Screw	Schraube Schraube Schraube	M6S 6x12 RFR M6S 6x20 RFR M6S 6x40 RFR		
725 24 49-40 725 24 53-40 725 24 69-40	Skruv Skruv Skruv	Screw Screw Screw	Schraube Schraube Schraube	M6S 8x16 RFR M6S 8x25 RFR M6S 8x90 RFR		
725 24 95-40 725 25 11-40	Skruv Skruv	Screw Screw	Schraube Schraube	M6S 10x30 RFR M6S 10x100 RFR		
731 23 10-40 731 23 12-40 731 23 16-40	Mutter Mutter Mutter	Nut Nut Nut	Mutter Mutter Mutter	M6M 3 RFR M6M 4 RFR M6M 6 RFR		
731 23 18-40	Mutter	Nut	Mutter	M6M 8 RFR		
731 23 20-40	Mutter	Nut	Mutter	M6M 10 RFR		
735 11 36-40 735 11 46-40 735 11 53-40	Fjäderbricka Fjäderbricka Fjäderbricka	Elastic washer Elastic washer Elastic washer	Federscheibe Federscheibe Federscheibe	FBB 4,1 RFR FBB 5,1 RFR FBB 6,1 RFR		
735 11 64-40 735 11 73-40	Fjäderbricka Fjäderbricka	Elastic washer Elastic washer	Federscheibe Federscheibe	FBB 8,2 RFR FBB 10.2 RFR		

Fet stil = Ändring

Bold print = Change

Fettdruck = Änderung

Fästelement Attachment element Befestigungsteile				Utgåva Edition Ausgabe 2	Månad Month Monat 12	År Year Jahr 2004
Art.nr Art. no Art. Nr	Benämning	Description	Bezeichnung	Anm. Notes Anm.		
724 32 87-40	Skruv	Screw	Schraube	MFX 4x8 RFR		
724 32 93-40	Skruv	Screw	Schraube	MFX 4x16 RFR		
724 33 31-40	Skruv	Screw	Schraube	MFX 5x12 RFR		
724 33 35-40	Skruv	Screw	Schraube	MFX 5x30 RFR		
724 33 64-40	Skruv	Screw	Schraube	MFX 6x10 RFR		



PLATON SERVICE
8 (800) 500-34-41
www.platonservice.com

Fet stil = Ändring
 Bold print = Change
 Fettdruck = Änderung

